

IACS Common Structural Rules for Double Hull Oil Tankers, January 2006

Background Document

APPENDIX C – FATIGUE STRENGTH ASSESSMENT

NOTE:

- This TB is published to improve the transparency of CSRs and increase the understanding of CSRs in the industry.
- The content of the TB is not to be considered as requirements.
- This TB cannot be used to avoid any requirements in CSRs, and in cases where this TB deviates from the Rules, the Rules have precedence.
- This TB provides the background for the first version (January 2006) of the CSRs, and is not subject to maintenance.

IACS

INTERNATIONAL ASSOCIATION OF CLASSIFICATION SOCIETIES LTD.

© IACS - the International Association of Classification Societies and the International Association of Classification Societies Limited

All rights reserved.

Except as permitted under current English legislation no part of this work may be photocopied, stored in a retrieval system, published, performed in public, adapted, broadcast, transmitted, recorded or reproduced in any form or by means, without prior permission of the copyright owner.

Where IACS has granted written permission for any part of this publication to be quoted such quotation must include acknowledgement to IACS.

Enquiries should be addressed to the Permanent Secretary,
International Association of Classification Societies Ltd,
36 Broadway
London, SW1H 0BH
Telephone: +44 (0)20 7976 0660
Fax: +44 (0)20 7808 1100
Email: PERMSEC@IACS.ORG.UK

Terms and Conditions

The International Association of Classification Societies (IACS), its Member Societies and IACS Ltd. and their directors, officers, members, employees and agents (on behalf of whom this notice is issued) shall be under no liability or responsibility in contract or negligence or otherwise howsoever to any person in respect of any information or advice expressly or impliedly given in this document, or in respect of any inaccuracy herein or omission herefrom or in respect of any act or omission which has caused or contributed to this document being issued with the information or advice it contains (if any).

Without derogating from the generality of the foregoing, neither the International Association of Classification Societies (IACS) nor IACS Ltd. nor its Member Societies nor their directors, officers, members, employees or agents shall be liable in contract or negligence or otherwise howsoever for any direct, indirect or consequential loss to any person caused by or arising from any information, advice, inaccuracy or omission given or contained herein or any act or omission causing or contributing to any such information, advice, inaccuracy or omission given or contained herein.

Any dispute concerning the provision of material herein is subject to the exclusive jurisdiction of the English courts and will be governed by English Law.

TABLE OF CONTENTS:

| | | |
|----------|--|-----------|
| 1 | NOMINAL STRESS APPROACH | 4 |
| 1.1 | General..... | 4 |
| 1.2 | Corrosion Model | 4 |
| 1.3 | Loads..... | 4 |
| 1.4 | Fatigue Damage Calculation | 5 |
| 1.5 | Classification of Structural Details | 7 |
| 1.6 | Other details..... | 10 |
| 2 | HOT SPOT STRESS (FE BASED) APPROACH | 11 |
| 2.1 | General..... | 11 |
| 2.2 | Corrosion Model | 11 |
| 2.3 | Loads..... | 11 |
| 2.4 | Fatigue Damage Calculation | 11 |
| 2.5 | Detail Design Standard | 12 |
| 3 | REFERENCES | 12 |

1 NOMINAL STRESS APPROACH

1.1 General

1.1.1 Applicability

- 1.1.1.a The scope of this Appendix is in line with current classification procedure and industry standard.
- 1.1.1.b The S-N curves are applicable for construction steel with yield strength less than 400N/mm².
- 1.1.1.c For steel with yield strength higher than 400N/mm², data from an approved test program or fracture mechanics analysis method which includes the effects of environment, cathodic protection level and temperature, should be used to establish the fatigue design parameters. It is subjected to acceptance of each Classification Society provided that the above data is collected and fatigue design parameters are submitted.

1.1.2 Assumptions

- 1.1.2.a The main assumptions employed in the fatigue approach are listed below:
 - (a) A linear cumulative damage model (i.e. Palmgren-Miner's Rule) has been used in connection with the S-N data.
 - (b) For longitudinal stiffener end connections, nominal stresses obtained by empirical formula and rule based loads form the basis of nominal stress based fatigue assessment.
 - (c) The long-term stress ranges of a structural detail can be characterized using a modified Weibull probability distribution parameter, ξ .
 - (d) Structural details are idealised and grouped into classes.
 - (e) The design life of the vessel is taken to be 25 years.
- 1.1.2.b The structural detail classification is based on joint geometry under simple loadings. Where the loading or geometry is too complex for a simple classification, a finite element analysis of the detail is to be carried out to determine the fatigue stress of that detail.
- 1.1.2.c A finite element analysis approach to determine hot-spot stresses has been applied. The method is used for weld toe locations that are typically found at welded hopper knuckle connections in way of transverse primary support members.

1.2 Corrosion Model

1.2.1 Net thickness

- 1.2.1.a See *Section 6/3*

1.3 Loads

1.3.1 General

- 1.3.1.a The main contributory loads to fatigue damage in oil tankers are considered to be the ones specified in 9/1.3.1.2, and as such, shall be used to establish the fatigue assessment standard of these Rules.

1.3.2 Selection of loading conditions

- 1.3.2.a The two most representative loading conditions are chosen. The vessels covered by these rules will normally operate in either fully loaded condition or normal ballast condition. (This is also in line with IACS Rec. 56., reference (a)) For different type of vessels (e.g., floating storage vessels, chemical tankers and bulk carriers) or vessels with different intended operation, the selection of loading conditions may be considered differently.
- 1.3.2.b The draft at midship is chosen to provide a clear design basis for the vessel and is in line with current practice.

1.3.3 Determination of loads

- 1.3.3.a It is considered that for this topic, no information in addition to that shown in the Rules is necessary to explain the background.

1.3.4 Vertical wave bending moment

- 1.3.4.a It is considered that for this topic, no information in addition to that shown in the Rules is necessary to explain the background.

1.3.5 Horizontal wave bending moment

- 1.3.5.a It is considered that for this topic, no information in addition to that shown in the Rules is necessary to explain the background.

1.3.6 Dynamic wave pressure

- 1.3.6.a The stretching of the external pressure above the water line and the reduction below the water line is used to take the intermittent wet and dry area into account. The height of this area is based on hydrostatic head of the pressure at the water line with a probability of exceedance of 10^{-4} . For simplicity, it is considered adequate to assume the pressure distribution in this area to be linear.

1.3.7 Dynamic tanks pressure

- 1.3.7.a It is considered that for this topic, no information in addition to that shown in the Rules and the background document for Section 7 is necessary to explain the background.

1.4 Fatigue Damage Calculation

1.4.1 Fatigue strength determination

- 1.4.1.a The Palmgren-Miner cumulative damage rule is generally accepted in industry and used in current practice by most of the classification societies.
- 1.4.1.b The formula for the number of cycles, N_L , is taken from IACS Rec. 56 and verified by direct calculation.
- 1.4.1.c The basic formula for Weibull shape parameter is taken from IACS Rec. 56. Based on direct calculations, this parameter is modified for side shell, longitudinal bulkheads and bottom structures. Based on calibration, this parameter is also adjusted for the bottom.

1.4.1.d The allowance of 15% of vessel service life for time not at sea is consistent with IACS Rec. 56.

1.4.2 Stresses to be used

1.4.2.a It is considered that for this topic, no information in addition to that shown in the Rules is necessary to explain the background.

1.4.3 Nominal stress calculation

1.4.3.a It is considered that for this topic, no information in addition to that shown in the Rules is necessary to explain the background.

1.4.4 Definition of stress component

1.4.4.a The stress calculation is based on linear beam theory for the longitudinal stiffener and for the hull girder. Some special corrections are made in order to apply the nominal stress with basic S-N curves.

1.4.4.b For calculation of effective span and spacing, reference is made to *Section 4/2*.

1.4.4.c The K_n factor, reference (b)

- (a) The K_n factor takes into account the warping effect due to unsymmetrical stiffener.
- (b) In panel stiffeners of unsymmetrical cross-section, the lateral panel loading exerts a horizontal loading on the stiffener flange making the stiffener deflect horizontally in warping.
- (c) The horizontal deflection and thus also the magnitude of the warping stress of the stiffener flange is constrained by the bending stiffness of the stiffener web and the attached plate flange.
- (d) This constraining effect of the stiffener web and attached flange on the warping response, represented by the K_n factor in these rules, has been derived based on the theory of beams on elastic foundation.

1.4.4.d The bulkhead factor, K_d , is derived based on cargo hold FEM study, considering the effect on bending stress in longitudinal stiffeners caused by relative deformation between supports.

1.4.4.e Stress combination factors, reference (f)

- (a) Stress range combination factors are derived based on the theory of a stationary ergodic narrow-banded Gaussian process.
- (b) The total combined stress in short-term sea states is expressed by linear summation of the component stresses with the corresponding combination factors. This expression is proven to be mathematically exact when applied to a single random sea.
- (c) The long-term total stress is similarly expressed by linear summation of component stresses with appropriate combination factors.

1.4.4.f The environment factor, f_{SN} , is required in order to account the fatigue behaviour of joints operating under an unprotected environment for part of the design life.

- (a) For the purpose of establishing a fatigue performance benchmark for these Rules, it is assumed that joints are operating under a protected environment for 20 years of the design life time and an unprotected environment 5 years of the design life time.

- (b) The S-N curves specified in the Rules are based on U.K. Department of Energy Offshore Installations Guidance on design, construction and certification, Fourth edition, 1990 (reference (d)). In the same Guidance, the following recommendations are given:
- For unprotected joints exposed to sea water the basic S-N curve is reduced by a factor of 2 on life for all joint classes.
(Note: for high strength steels, i.e., $\sigma_y > 400\text{N/mm}^2$, a reduction factor of 2 may not be adequate).
 - In addition, there will be no slope change for the S-N curve in the case of unprotected joints in sea water.
- (c) As described in Reference (c), the fatigue life for unprotected joints can be calculated by using the S-N curve at protected environment and reduced by approximately factor of 2 (a factor of 2 on life is an approximation due to the fact that the S-N curve in unprotected condition has no slope change). To reflect the application of this factor of 2 for 5 years of design life, f_{SN} , is applied to the calculated stress range based on the cubic relationship between stress and fatigue life. f_{SN} is then obtained as $[(20+5x2)/25]^{1/3} = 1.06$.

1.4.5 Selection of S-N curves

- 1.4.5.a The basic design S-N curves are adapted from the fatigue data published in the UK HSE Guidance Notes for Design, Construction and Classification of Offshore Installations, 4th edition, 1990.
- 1.4.5.b It is an industry standard to use the design S-N curves, which correspond to a survival probability of 97.7 per cent.
- 1.4.5.c The effect of mean stress is adapted from UK Department of Energy Background to New Fatigue Design Guidance for Steel Welded Joints in Offshore Structures, 1984. Reference (e).
- 1.4.5.d The effect of plate thickness is adapted from UK HSE Guidance Notes for Design, Construction and Classification of Offshore Installations, 4th edition, 1990.
- 1.4.5.e The effect of grinding of welds is recognized. However, the grinding of welds should not be used as a “design tool”, but rather as a means to improve the fatigue life when circumstances indicate that this is necessary.

1.5 Classification of Structural Details

1.5.1 General

- 1.5.1.a The recommendations in this Section are mostly adapted from publications of the U.K. Health and Safety Executive, but also reflecting current classification society practice.
- 1.5.1.b The 10 mm limit criterion in Table C.1.7 Notes Item 2 is based on U.K. DEn recommendation, Reference (d).

As explained in DEn, an edge distance criterion exists to limit the possibility of local stress concentrations occurring at unwelded edges as a result, for example, of undercut, weld spatter, or accidental overweave in manual fillet welding. When the welds are on or adjacent to the edge of the stressed member, the stress concentration is increased and the fatigue performance is reduced and this must be separately

assessed and included in the calculation of applied stress or the detail reclassified as in DEn and included in the CSR Tanker criteria

- 1.5.1.c For soft toe design, reference is made to International Institute of Welding IIW document XIII-1539-95 / XV-845-95 Recommendations on Fatigue of Welded Components, 1995. Reference (c)
- 1.5.1.d Collar connection:
- (a) A comparative FEM hotspot stress analysis has been carried out for a typical collared and lugged connection respectively. The conclusion from this study supports the assignment of a higher S-N class to collared connections under axial loads.
 - (b) An F class is proposed for collared connections under predominantly axial load, while an F2 class is proposed for collared connections under a combination of bending loads and axial loads. The effect of the collar on the hotspot stress in way of pillar stiffener toe is not significant, and the S-N class should be maintained i.e. F2 for both axial and bending modes.
- 1.5.1.e “Pillar-less” connection:
- (a) Omitting or off-setting the web stiffener from the longitudinal stiffener face plate has the effect of creating a potential critical location in way of the longitudinal stiffener slot/lug connection.
 - (b) For this reason where lateral pressure load is significant, e.g. side shell, bottom and inner bottom etc., pillar-less connections are not recommended unless adequate provisions are made to minimise the hotspot stress around the slot/lug connections. Adoption of slot/lug geometry optimised to soften the hotspot stresses is considered such an adequate provision.
 - (c) Examples of detail design of “pillar-less” connection are indicated in Figure C.1.11.a.
- 1.5.1.f Joint class for optimised slot/lug design is mainly based on current classification society practice.

Figure C.1.11.a
Example Detail Design for Cut Outs

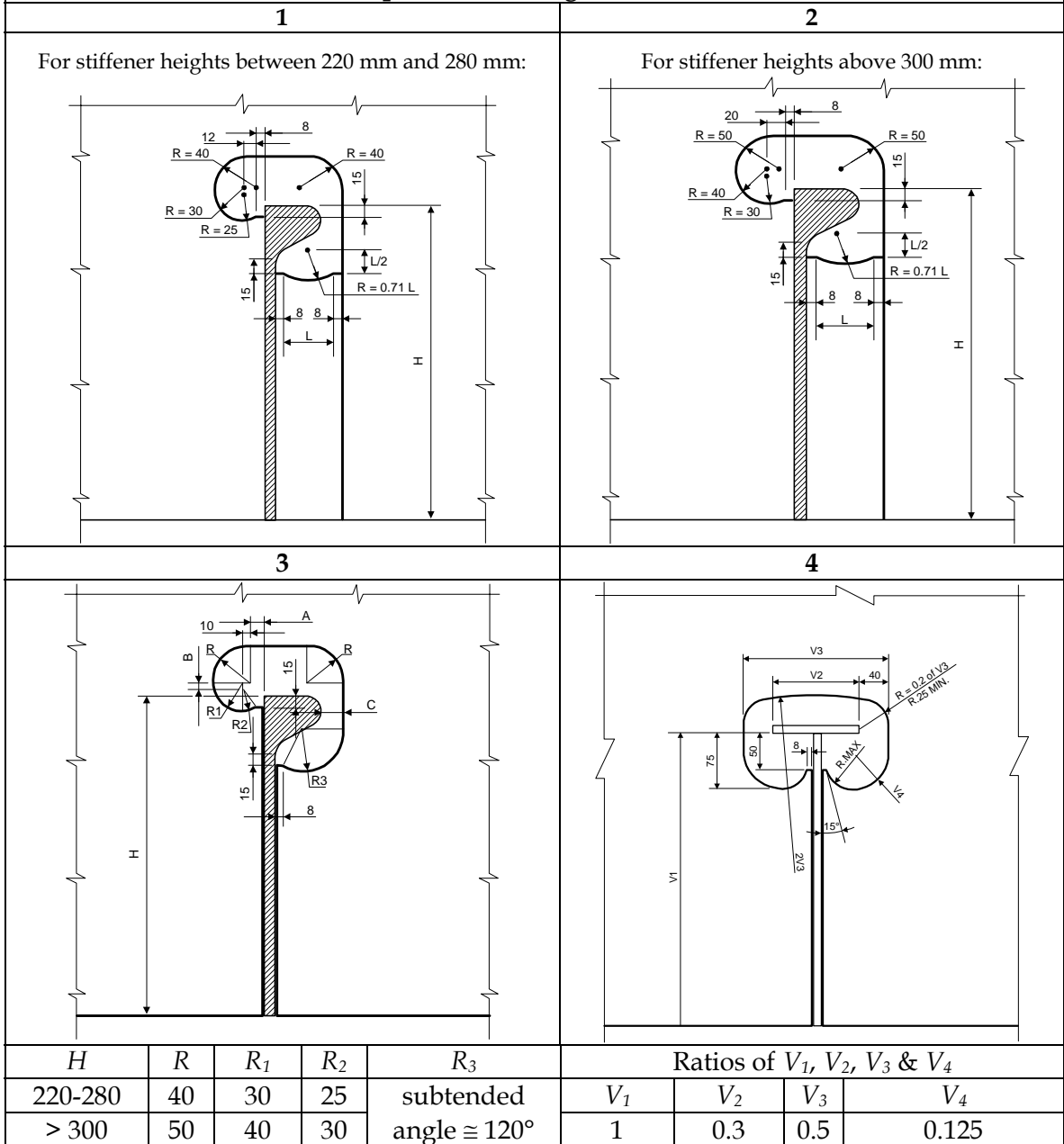
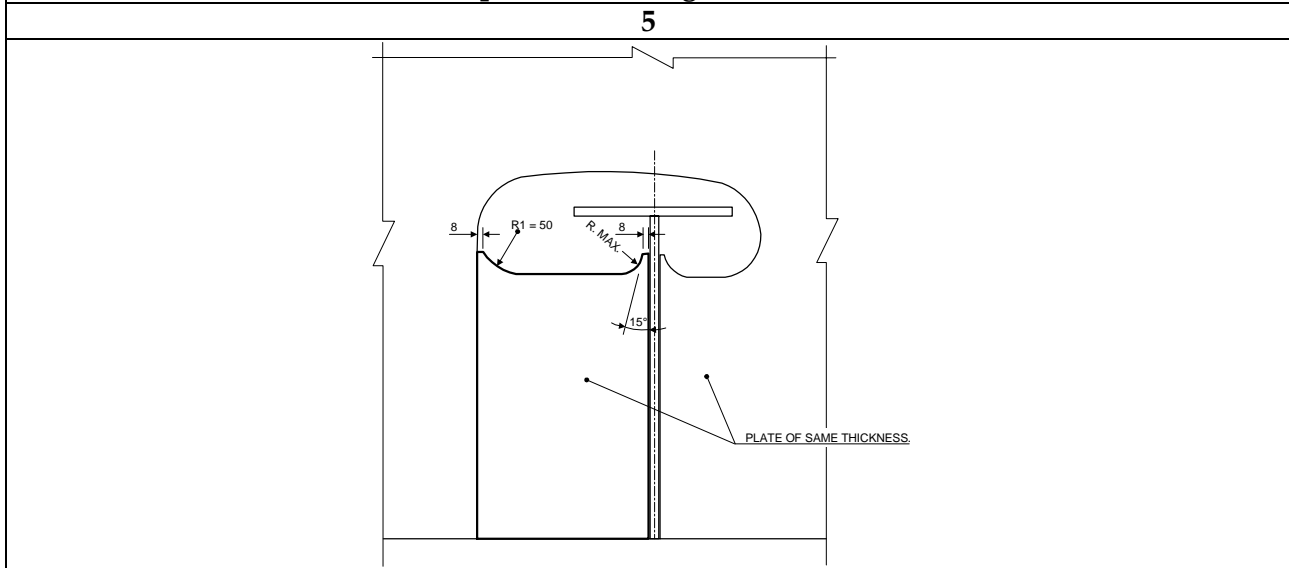

Figure C1.11.a (Continued)
Example Detail Design for Cut Outs



1.6 Other details

1.6.1 Scallops in way of block joints

- 1.6.1.a Terminating the block joint butt weld on a stress raiser such the edge of a scallop is to be avoided unless the hull girder modulus indicates that it is acceptable for an F2 joint class. Alternative means of termination of the block joint butt are given.

2 HOT SPOT STRESS (FE BASED) APPROACH

2.1 General

2.1.1 Applicability

2.1.1.a It is considered that for this topic, no information in addition to that shown in the Rules is necessary to explain the background.

2.1.2 Assumptions

2.1.2.a See 1.1.2

2.2 Corrosion Model

2.2.1 Net thickness

2.2.1.a See Section 6/3

2.3 Loads

2.3.1 General

2.3.1.a See 1.3

2.4 Fatigue Damage Calculation

2.4.1 Fatigue strength determination

2.4.1.a See 1.4.1

2.4.2 Stresses to be used

2.4.2.a The extrapolation point for hot spot stress is based on a study carried out during the Rule development work.

2.4.2.b The stress range combination factor is developed based on the same theory as in 1.4.2.

2.4.2.c The selection of stress along the direction perpendicular to the weld is valid for welded hopper knuckle connections.

2.4.2.d Since crack initiates from the weld toe along the surface and propagates through thickness, it is more appropriate to use surface stress as fatigue stress in connection with hot spot stress approach.

2.4.2.e The approach in this section generally builds on the findings contained in reference (g), and also reflecting current classification society practice.

2.4.3 Selection of S-N curves

2.4.3.a The selection of Class D S-N curve for hot spot stress analysis is based on a study carried out during the Rule development work.

2.4.3.b The approach in this section generally builds on the findings contained in reference (g), and also reflecting current classification society practice.

2.5 Detail Design Standard

2.5.1 Hopper knuckles

2.5.1.a The detail design of hopper knuckles is in line with current best practice and reflecting classification society recommendation from damage experience.

2.5.2 Transverse Bulkhead Horizontal Stringer Heel

2.5.2.a The detail design of transverse bulkhead horizontal stringer heel is in line with current best practice and reflecting classification society recommendation from damage experience.

2.5.3 Transverse and Longitudinal Corrugated Bulkhead Connection to Lower Stool

2.5.3.a The detail design of transverse and longitudinal corrugated bulkhead connection to lower stool is in line with current best practice and reflecting classification society recommendation from damage experience.

3 REFERENCES

- (a) IACS Rec. 56 "Fatigue Assessment of Ship Structures", July 1999
- (b) The Elastic Bending Response of Panel Stiffeners of Unsymmetrical Cross-Section Subjected to Uniform Lateral Pressure loads. DNV Technical Report. No.2004-1150, rev.01, 2004
- (c) International Institute of Welding IIW document XIII-1539-95 / XV-845-95 Recommendations on Fatigue of Welded Components, 1995
- (d) U.K. Department of Energy Offshore Installations: Guidance on design, construction and certification, Fourth edition, 1990
- (e) UK Department of Energy Background to New Fatigue Design Guidance for Steel Welded Joints in Offshore Structures, 1984
- (f) Proposal to IACS by Joint Tanker Project: Technical Background of Load/Stress Combination Factor for Fatigue Assessment (Draft), 2004
- (g) Hot Spot Stress Analysis of Five Structural Details and Recommendations for Modelling, Stress Evaluation and Design S-N Curve. Germanischer Lloyd Report No. FF99.188.A Version 1/2000-02-16. Joint Industry Project FPSO Fatigue Capacity – Special Task Group on Hot Spot Stress Approach.