

Requirements
concerning
MOBILE OFFSHORE
DRILLING UNITS

CONTENTS

Note: The contents of this section are treated as one complete Requirement.

D1	Requirement concerning offshore drilling units and other similar units	Rev.4	July 2004
D2	Definitions	Rev. 2	1996
D3	General design parameters	Rev.5	Jan 2012
D4	Self-elevating drilling units	Rev.3	Jan 2012
D5	Column stabilized drilling units	Rev. 3	1996
D6	Surface type drilling units	Rev.1	Jan 2012
D7	Watertight integrity	Rev.3	Jan 2012
D8	Hazardous areas	Rev. 2	1996
D9	Machinery	Rev. 3	1996
D10	Electrical installations	Rev.2	1990
D11	Safety features	Rev.3	Jan 2012
D12	Deleted 1999 (re-located to UR Z15)		

The purpose of these Requirements is to provide a common basis for the Classification of Mobile Offshore Drilling Units and Other Similar Units, by specifying minimum standards for their design, equipment and construction, to be incorporated in the Rules of the individual Member Societies of the International Association of Classification Societies (IACS).

In order to facilitate the future development of these units, emphasis has been placed on specifying general structural design principles, where possible, rather than individual scantlings. The Requirements, therefore, provide a broad and flexible basis on which present and future structures may be designed and developed.

The machinery requirements are primarily intended to apply to the propulsion machinery such as that used for drilling operations, except in so far as such items may affect the safety of the unit on which they are installed.

Such equipment and systems may be designed to the alternative requirements of recognized standards acceptable to the Society.

D1 Requirement concerning offshore drilling units and other similar units

(1979)
(Rev. 1
1987)
(Rev. 2
1990)
(Corr.
1995)
(Rev.3,
1996)
(Rev.4
July
2004)

Conditions of classification

D1.1 Class designation

D1.1.1 General

These Requirements have been developed for units intended to engage in offshore drilling operations, and the text reflects that development. The Requirements are to be considered as minima by the member Societies of the International Association of Classification Societies (IACS). The Rules of an individual Society may specify requirements which exceed those contained herein. In addition, particular National Governments may have regulations which might be in excess of these Requirements.

Each member Society is prepared to offer assistance, upon the request of an owner or designer, in evaluating a specific design against published National regulations. These Requirements shall not apply to those units contracted for construction prior to the effective date of their adoption into the Rules, unless specially requested by an owner.

Mobile offshore drilling units built in accordance with the Rules or their equivalent will then be assigned a class symbol by the Society, followed by an appropriate designation applicable to the type of unit being classed.

Units will be retained in classification provided they are found to be maintained in accordance with the Rules upon completion of prescribed Surveys in accordance with D-12.

D1.1.2 Other similar units

Other special purpose units, which do not engage in drilling operations but which have configurations and modes of operation similar to drilling units, may be considered for classification by the Society, on the basis of the Requirements as found to be applicable, and the relevant Rules. In addition, evaluation must be made of other possible loading conditions peculiar to the type of unit under consideration. Calculations substantiating the adequacy of the design are to be submitted to the Society. Machinery and electrical installations, etc., for other special purpose units will be subject to approval by the Society, as found to be applicable.

D1.1.3 Items covered by the Requirements

The items listed below, where applicable, are covered by the Requirements and are subject to approval by the Society:

- Material
- Structural strength
- Welding
- Stability, intact and damaged
- Weathertight/watertight integrity
- Temporary or emergency mooring equipment
- Jacking system
- Propulsion machinery, including shafts and propellers
- Steering gear and rudders
- Auxiliary machinery
- Pumping and piping systems, including valves
- Boilers and Pressure Vessels
- Electrical installations
- Protection against fire and explosion

Note:

1) The “contracted for construction” date means the date on which the contract to build the vessel is signed between the prospective owner and the shipbuilder. For further details regarding the date of “contract for construction”, refer to IACS Procedural Requirement (PR) No. 29.

The Requirements do not cover structural details of industrial items used exclusively in drilling or related operations. Machinery, electrical and piping systems used exclusively for industrial purposes are not covered by the Requirements, except in so far as their design or arrangement may affect the safety of the unit. Determination of the adequacy of sea bed conditions, regarding bearing capacity, resistance to possible sliding and anchor holding capability, is not covered by the Requirements. The assessment of the required holding capacity, arrangement and operation of position mooring equipment and dynamic positioning equipment used for station-keeping activities in connection with the unit's operation is the responsibility of the owner, and is not included in the Requirements.

D1.1.4 Ice strengthening

Units designed to be located in areas where ice strengthening may be necessary will be specially considered and, provided that the unit is reinforced as necessary for operation in the specified ice conditions to the satisfaction of the Society, an appropriate designation will be added to the descriptive notes published by the Society.

D1.1.5 Temporary or emergency mooring equipment

For purposes of temporary or emergency mooring, units are to be equipped with anchors and cables in accordance with the Rules.

D1.1.6 Requirements for position keeping systems and components are contained in D3.11.

D1.2 Novel features

D1.2.1 Units which contain novel features of design, with respect to buoyancy, elevating arrangements, structural arrangements, machinery, equipment, etc., to which the Requirements are not directly applicable, may be classed, when approved by the Society on the basis that the Rules, in so far as applicable, have been complied with and that special consideration has been given to the novel features based on the best information available at the time.

D1.3 Submissions

D1.3.1 Hull and structural plans and design data

Plans showing the scantlings, arrangements and details of the principal parts of the structure of each unit to be built under the Society's survey are to be submitted for approval before construction commences. These drawings are to clearly indicate the scantlings, types and grades of materials, joint details and welding, or other methods of connection. These plans are to include the following, where applicable:

- General arrangement
- Inboard and outboard profile
- Summary of distributions of fixed and variable weights
- Plan indicating design loading for all decks
- Transverse sections showing scantlings
- Longitudinal sections showing scantlings
- Decks, including helicopter deck
- Framing
- Shell plating
- Watertight bulkheads and flats
- Structural bulkheads and flats
- Tank boundaries with location of overflows
- Pillars and girders
- Diagonals and struts
- Legs
- Structure in way of jacking or other elevating arrangements
- Stability columns and intermediate columns
- Hulls, pontoons, footings, pads or mats

D1
cont'd

Superstructures and deck houses
 Arrangement and details of watertight doors and hatches
 Anchor handling arrangements
 Welding details and procedures
 Lines or offsets
 Curves of form or equivalent data
 Cross curves of stability or equivalent data
 Wind heeling moment curves or equivalent data
 Capacity plan
 Tank sounding tables
 Corrosion control arrangements
 Methods and locations for non-destructive testing

In addition to the above, an arrangement plan of watertight compartmentation should be submitted as early in the design stage as possible, for review of damage stability. This drawing is to indicate the watertight bulkheads, decks and flats and all openings therein. Doors, hatches, ventilators, etc., and their means of closure, are to be indicated. Piping and ventilation systems should be shown in sufficient detail to evaluate their effects on the watertight integrity of the unit after incurring damage.

D1.3.2 Machinery plans and data

Plans are to be submitted showing the arrangements and details of all propulsion and auxiliary machinery, steering gear, boilers and pressure vessels, electrical systems, jacking systems, bilge and ballast systems, fire extinguishing systems, and other pumps and piping systems as described in D9, D10 and D11 and as required by the Rules. A description of the jacking system is to be submitted.

D1.3.3 Calculations

The following data and calculations are to be submitted in conjunction with the scantling plans, as may be applicable:

- Structural analysis for relevant loading conditions
- Resultant forces and moments from wind, waves, current, mooring and other environmental loadings taken into account in the structural analysis.
- Effects of icing on structural loading, stability and windage area.
- Stability calculations, both intact and damaged, over the appropriate range of drafts, including the transit conditions.
- Significant operational loads from drilling derrick and associated equipment, such as riser tensioners, on supporting structures, and other similar type significant loadings.
- Calculations substantiating adequacy of structure to transmit forces between legs and hull through the jacking or other elevating system.
- Evaluation of the unit's ability to resist overturning while bearing on the sea bed.

Submitted calculations are to be suitably referenced. Results from relevant model tests or dynamic response calculations may be submitted as alternatives or as substantiation for the required calculations.

D1.4 Materials

D1.4.1 The Requirements are intended for units to be constructed of materials manufactured and tested in accordance with the Rules. Where it is intended to use materials manufactured by different processes or having different properties, their use will be specially considered by the Society.

D1.5 Welding

D1.5.1 Welding is to comply with the Rules. The Society is to be satisfied that all welders to be employed in the construction of units to be classed are properly qualified in

the type of work proposed and in the proper use of the welding processes and procedures to be followed. The methods and locations for non-destructive testing of welds are to be submitted to the Society.

D1.6 Testing

D1.6.1 Upon completion of work, compartments, decks, bulkheads, etc., are to be tested, as specified by the Society.

D1.7 Operating booklet

An Operating Booklet or equivalent is to be placed on board each unit. The booklet should include the following information, as applicable to the particular unit, so as to provide suitable guidance to the operating personnel with regard to safe operation of the unit:

General description of the unit

Pertinent data for each approved mode of operation, including design and variable loading, environmental conditions, assumed sea bed conditions, draft, etc.

Minimum anticipated atmospheric and sea temperatures.

General arrangement showing watertight compartments, closures, vents, allowable deck loadings, etc. If permanent ballast is to be used, the weight, location and substance used are to be clearly indicated.

Hydrostatic curves or equivalent data.

Capacity plan showing capacities of tanks, centres of gravity, free surface corrections, etc.

Instructions for operation, including precautions to be taken in adverse weather, changing mode of operations, any inherent limitations of operations, etc.

Plans and description of the ballast system and instructions for ballasting.

Hazardous areas plan.

Light ship data based on the results of an inclining experiment, etc.

Stability information in the form of maximum KG-draught curve, or other suitable parameters based upon compliance with the required intact and damaged stability criteria.

Representative examples of loading conditions for each approved mode of operation, together with means for evaluation of other loading conditions.

Details of emergency shutdown procedures for electrical equipment.

Identification of the helicopter used for the design of the helicopter deck.

D1.8 Construction Booklet

A set of plans showing the exact location and extent of application of different grades and strengths of structural materials, together with a description of the material and welding procedures employed, is to be placed aboard the unit. Any other relevant construction information is to be included in the booklet, including restrictions or prohibitions regarding repairs or modifications.

END

D2

(1979)
 (Rev. 1
 1990)
 Rev. 2
 1996)

Definitions**D2.1 General**

D2.1.1 The term 'unit' as used herein is intended to mean any mobile offshore structure or vessel, whether designed for operation afloat or supported by the sea bed, built in accordance with the Requirements and classed by a member Society, and includes the entire structure and components covered by the Requirements. The term 'drilling unit' as used herein means any unit intended for use in offshore drilling operations for the exploration or exploitation of the subsea resources. The term 'self-propelled unit' as used herein refers to a unit which is designed for unassisted passage. All other units are considered as non-self-propelled.

D2.1.2 The term 'Requirements' as used herein refers to the 'International Association of Classification Societies' requirements concerning mobile offshore drilling units and other similar units (D1 – D11).

D2.1.3 The term 'Society' as used herein refers to the individual member Classification Society.

D2.1.4 The term 'Rules' as used herein refers to the currently applicable Rules of the Society.

D2.2 Types of drilling units**D2.2.1 Self-elevating drilling units**

Self-elevating drilling units have hulls with sufficient buoyancy to safely transport the unit to the desired location, after which the hull is raised to a predetermined elevation above the sea surface on its legs, which are supported on the sea bed. Drilling equipment and supplies may be transported on the unit, or may be added to the unit in its elevated position. The legs of such units may penetrate the sea bed, may be fitted with enlarged sections or footings to reduce penetration, or may be attached to a bottom pad or mat.

D2.2.2 Column stabilized drilling units

Column stabilized drilling units depend upon the buoyancy of widely spaced columns for flotation and stability for all afloat modes of operation or in the raising or lowering of the unit, as may be applicable. The columns are connected at their top to an upper structure supporting the drilling equipment. Lower hulls or footings may be provided at the bottom of the columns for additional buoyancy or to provide sufficient area to support the unit on the sea bed. Bracing members of tubular or structural sections may be used to connect the columns, lower hulls or footings and to support the upper structure. Drilling operations may be carried out in the floating condition, in which condition the unit is described as a semisubmersible, or when the unit is supported by the sea bed, in which condition the unit is described as a submersible. A semisubmersible unit may be designed to operate either floating or supported by the sea bed, provided each type of operation has been found to be satisfactory.

D2.2.3 Surface type drilling units

- (a) Ship type drilling units are seagoing ship-shaped units having a displacement-type hull or hulls, of the single, catamaran or trimaran types, which have been designed or converted for drilling operations in the floating condition. Such types have propulsion machinery.
- (b) Barge type drilling units are seagoing units having a displacement type hull or hulls, which have been designed or converted for drilling operations in the floating condition. These units have no propulsion machinery.



D2.2.4 Other types of drilling units

Units which are designed as mobile offshore drilling units and which do not fall into the above mentioned categories will be treated on an individual basis and be assigned an appropriate classification designation.

D2.3 Dimensions**D2.3.1 General**

Extreme dimension, such as length, breadth, depth, etc., are used to define the overall size of the unit, and these together with other relevant dimensions, will be published by the Society.

D2.3.2 Draught

The moulded draught is the vertical distance measured from the moulded base line to the assigned load line. Certain components of a unit's structure, machinery or equipment may extend below the moulded base line.

D2.4 Water depth

D2.4.1 The water depth as used herein is the vertical distance from the sea bed to the mean low water level plus the height of astronomical and storm tides.

D2.5 Moulded base line

D2.5.1 The moulded base line is a horizontal line extending through the upper surface of the bottom plating.

D2.6 Lightweight

D2.6.1 Lightweight is defined as the weight of the complete unit with all its permanently installed machinery, equipment and outfit, including permanent ballast, spare parts normally retained on board and liquids in machinery and piping to their normal working levels, but does not include liquids in storage or reserve supply tanks, items of consumable or variable loads, stores or crew and their effects.

D2.7 Weathertight means that in any sea conditions water will not penetrate into the unit.

D2.8 Watertight means that capability of preventing the passage of water through structure in any direction under the head of water for which the surrounding structure is designed.

D2.9 Downflooding means any flooding of the interior or any part of the buoyant structure of a unit through openings which cannot be closed weathertight, watertight or which are required for operations reasons to be left open in all weather conditions, as appropriate for the intact and damage stability criteria.

D2.10 Modes of Operation

D2.10.1 A mode of operation is a condition or manner in which a unit may operate or function while on location or in transit. Insofar as the Requirements are concerned, the approved modes of operation of a unit should include the following:



D2
cont'd

- (i) Operating conditions: Conditions wherein a unit is on location for purposes of drilling or other similar operations, and combined environmental and operational loadings are within the appropriate design limits established for such operations. Unit may be either afloat or supported on the sea bed, as applicable.
- (ii) Severe storm conditions: A condition during which a unit may be subjected to the most severe environmental loadings for which the unit is designed. Drilling or similar operations may have been discontinued due to the severity of the environmental loadings. Unit may be either afloat or supported on the sea bed, as applicable.
- (iii) Transit conditions: All unit movements from one geographical location to another.



D3 General design parameters

(1979)

(Rev.1

1987)

(Rev.2

1989)

(Rev.3

1990)

(Rev.4

1996)

(Corr.

July

2001)

(Corr.2

Oct

2007)

(Rev.5

Jan

2012)

D3.1 Material

D3.1.1 Unless otherwise specified, the Requirements are intended for units to be constructed of hull structural steel, manufactured and having the properties as specified in the Rules. Where it is proposed to use steel or other material having properties differing from those specified in the Rules, the specification and properties of such material shall be submitted to the Society for consideration and special approval. Due consideration is to be given to the ratio of yield to ultimate strength of the materials to be used, and to their suitability with regard to structural location and to design temperatures.

D3.2 Scantlings

D3.2.1 Scantlings of the major structural elements of the unit are to be determined in accordance with the Requirements as set forth herein. Scantlings of structural elements which are subject to local load only, and which are not considered to be effective components of the primary structural frame of the unit, shall comply with the applicable requirements of the Rules.

D3.2.2 Surface type drilling units are to have scantlings that meet the Rules. Also, special consideration is to be given to the items noted in D6.

D3.2.3

- (a) Where the unit is fitted with an acceptable corrosion protection system, the scantlings may be determined from D3.4 in conjunction with allowable stresses given in D3.5, in which case no corrosion allowance is required. If scantlings are determined from the Rules, reductions for corrosion protection may be as permitted by the Rules.
- (b) Where no corrosion protection system is fitted or where the system is considered by the Society to be inadequate, an appropriate corrosion allowance will be required on scantlings determined from D3.4 and D3.5, and no reduction will be permitted on scantlings determined by the use of the Rules.

Notes:

1. This UR apply to mobile offshore drilling units contracted for construction on and after 1 January 2013.
2. The "contracted for construction" date means the date on which the contract to build the vessel is signed between the prospective owner and the shipbuilder. For further details regarding the date of "contract for construction", refer to IACS Procedural Requirement (PR) No. 29.

D3
(cont)**D3.3 Structural design loadings**

D3.3.1 General

A unit's modes of operation are to be investigated using realistic loading conditions, including gravity loadings together with relevant environmental loadings due to the effects of wind, waves, currents, ice and, where deemed necessary by the owner (designer), the effects of earthquake, sea bed supporting capabilities, temperature, fouling, etc. Where applicable, the design loadings indicated herein are to be adhered to for all types of mobile offshore drilling units. The owner (designer) will specify the environmental conditions for which the unit is to be approved. Where possible, the design environmental criteria determining the loads on the unit and its individual elements should be based upon significant statistical information and should have a return period (period of recurrence) of at least 50 years for the most severe anticipated environment. If a unit is restricted to seasonal operations in order to avoid extremes of wind and wave, such seasonal limitations must be specified.

D3.3.2 Wind loadings

Sustained and gust velocities, as relevant, are to be considered when determining wind loadings. Sustained wind velocities specified by the owner (designer) are not to be less than 25,8 m/s (50 knots). However, for unrestricted service, the wind criteria for intact stability given in D3.7.2 are also to be applicable for structural design considerations, for all modes of operation, whether afloat or supported by the sea bed. Pressures and resultant forces are to be calculated to the satisfaction of the Society. Where wind tunnel data obtained from tests on a representative model of the unit by a recognized laboratory are submitted, these data will be considered for the determination of pressures and resulting forces.

D3.3.3 Wave loadings

- (a) Design wave criteria specified by the owner (designer) may be described either by means of design wave energy spectra or deterministic design waves having appropriate shape, size and period. Consideration is to be given to waves of less than maximum height where, due to their period, the effects on various structural elements may be greater.
- (b) The forces produced by the action of waves on the unit are to be taken into account in the structural design, with regard to forces produced directly on the immersed elements of the unit and forces resulting from heeled positions or accelerations due to its motion. Theories used for the calculation of wave forces and selection of relevant coefficients are to be acceptable to the Society.
- (c) Consideration is to be given to the possibility of wave induced vibration.

D3.3.4 Current loadings

Consideration should be given to the possible superposition of current and waves. In those cases where this superposition is deemed necessary, the current velocity should be added vectorially to the wave particle velocity. The resultant velocity is to be used to compute the total force.

D3.3.5 Loadings due to vortex shedding

Consideration should be given to the possibility of flutter of structural members due to von Karman vortex shedding.

D3
(cont)**D3.3.6 Deck loadings**

As indicated in D1.3, a loading plan is to be prepared for each design. This plan is to show the maximum design uniform and concentrated loadings for all areas for each mode of operation. Design loadings are not to be less than:

- (i) Crew spaces (walkways, general traffic areas, etc.)

4,5 kN/m² (94 lb/ft²)

- (ii) Work areas

9 kN/m² (188 lb/ft²)

- (iii) Storage areas

13 kN/m² (272 lb/ft²)

- (iv) Helicopter platform

2 kN/m² (42 lb/ft²)

D3.4 Structural analysis

D3.4.1 The primary structure of the unit is to be analysed using the loading conditions stipulated below and the resultant stresses are to be determined. Sufficient conditions, representative of all modes of operation, are to be considered, to enable critical design cases to be determined. Calculations for relevant conditions are to be submitted for review. The analysis should be performed using an appropriate calculation method and should be fully documented and referenced.

For each loading condition considered, the following stresses are to be determined for comparison with the appropriate allowable stresses given in D3.4.3 or D3.5:

- (i) Stresses due to static loadings only, in calm water conditions, where the static loads include service load such as operational gravity loadings and weight of the unit, with the unit afloat or resting on the sea bed, as applicable.
- (ii) Stresses due to combined loadings, where the applicable static loads in (i) are combined with relevant design environmental loadings, including acceleration and heeling forces.

D3.4.2

- (a) Local stresses, including those due to circumferential loading on tubular members, are to be added to the primary stresses to determine total stress levels.
- (b) The scantlings are to be determined on the basis of criteria which combine, in a rational manner, the individual stress components acting on the various structural elements of the unit. This method is to be acceptable to the Society. (See D3.4.3)
- (c) The critical buckling stress of structural elements is to be considered, where appropriate, in relation to the computed stresses.

D3 (cont)

- (d) When computing bending stresses, the effective flange areas are to be determined in accordance with 'effective width' concepts acceptable to the Society. Where appropriate, elastic deflections are to be taken into account when determining the effects of eccentricity of axial loading, and the resulting bending moments superimposed on the bending moments computed for other types of loadings.
- (e) When computing shear stresses in bulkheads, plate girder webs of hull side plating, only the effective shear area of the web is to be considered. In this regard, the total depth of the girder may be considered as the web depth.

D3.4.3

- (a) For plated structures, members may be designed according to the von Mises equivalent stress criterion, where the equivalent stress σ_e is defined as follows:

$$\sigma_e = \sqrt{\sigma_x^2 + \sigma_y^2 - \sigma_x \sigma_y + 3\tau_{xy}^2}$$

where

σ_x = stress in the x direction

σ_y = stress in the y direction

τ_{xy} = shear stress in the x-y plane.

The equivalent stress in plate elements clear of discontinuities should generally not exceed 0,7 and 0,9 of the yield strength of the material, for the loading conditions given in D3.4.1(i) and (ii), respectively.

- (b) Members of lattice type structures should be designed in accordance with accepted practice for such members; for example, they may comply with the American Institute of Steel Construction's Specifications for the Design, Fabrication and Erection of Structural Steel for Buildings.

D3.4.4 Fatigue Analysis

D3.4.4.1 The possibility of fatigue damage due to cyclic loading should be considered in the design of self elevating and column stabilized units.

D3.4.4.2 The fatigue analysis will be dependent on the intended mode and area of operations to be considered in the unit's design.

D3.4.4.3 The fatigue life is to be based on a period of time equal to the specified design life of the structure. The period is normally not to be taken as less than 20 years.

D3.4.5 The effect of notches, stress raisers and local stress concentrations is to be taken into account in the design of load carrying elements.

D3.4.6 Critical joints depending upon transmission of tensile stresses through the thickness of the plating of one of the members (which may result in lamellar tearing) are to be avoided wherever possible. Where unavoidable, plate material with suitable through-thickness properties and inspection procedures may be required.

D3 (cont)

D3.5 Allowable stresses

D3.5.1 For cases involving individual stress components and, where applicable, direct additions of such stresses, the stress is not to exceed the allowable individual stress σ_i^* or τ_i^* .

where

$\sigma_i^* = \eta \sigma_y$ for axial bending stress

$\tau_i^* = \eta \sigma_y \Pi$ for shear stress

σ_y = specified minimum tensile yield stress of the material

η = usage factor

for static loadings (see D3.4.1 (i))

η = 0,6 for axial stress

0,6 for bending stress

0,40 for shear stress

for combined loadings (see D3.4.1 (ii))

η = 0,8 for axial stress

0,8 for bending stress

0,53 for shear stress

D3.5.2 In addition, the stress in structural elements, due to compression, ending, shear or any combination of the three, shall not exceed the allowable buckling stress σ_b^* or τ_b^*

where

$\sigma_b^* = \eta \sigma_{cr}$ for compression or bending

$\tau_b^* = \eta \tau_{cr}$ for shear

η = 0,6 for static loadings

η = 0,8 for combined loadings

σ_{cr} or τ_{cr} = critical compressive buckling stress or shear buckling stress, respectively, σ_y is as defined in D3.5.1.

D3 (cont)

D3.5.3 In addition, when structural members are subjected to axial compression or combined axial compression and bending, the extreme fibre stresses shall comply with the following requirement:

$$\sigma_a / \sigma_a^* + \sigma_{ab} / \sigma_{ab}^* \leq 1,0$$

where

σ_a = computed axial compressive stress

σ_{ab} = computed compressive stress due to bending

$\sigma_{ab}^* = \sigma_i^*$ or σ_b^* for bending stress, as defined in D3.5.1 or D3.5.2

$\sigma_a^* = \eta \sigma_{cr,i} (1 - 0,13\lambda / \lambda_0)$ if $\lambda < \lambda_0$

$\sigma_a^* = \eta \sigma_{cr,e} 0,87$ if $\lambda \geq \lambda_0$

σ_a^* shall not exceed σ_{ab}^*

$$\lambda = kl/r$$

$$\lambda_0 = \sqrt{2\pi^2 E / \sigma_y}$$

$\sigma_{cr,i}$ = inelastic column critical buckling stress

$\sigma_{cr,e}$ = elastic column critical buckling stress

η is as defined in D3.5.2

kl = effective unsupported length

r = governing radius of gyration associated with kl

E = modulus of elasticity of the material

σ_y is as defined in D3.5.1.

D3.5.4 Unstiffened or ring-stiffened cylindrical shells subjected to axial compression or compression due to bending, and having proportions which satisfy the following relationship:

$$D/t > E/9\sigma_y$$

where

D = mean diameter

t = wall thickness

(D and t expressed in the same units)

D3
(cont)

σ_y is as defined in D3.5.1

E is as defined in D3.5.3

(σ_y and E expressed in the same units)

are to be checked for local buckling in addition to the overall buckling as specified in D3.5.3.

D3.5.5 Designs based upon novel methods, such as plastic analysis or elastic buckling concepts, will be specially considered.

NOTE 1

The allowable stresses as stated in D3.5 are intended to reflect uncertainties in environmental data, determination of loadings from the data and calculation of stresses which may exist at the present time. It is envisioned that the Requirements may eventually allow for the adoption of separate load factors or usage factors for the above influences, so that allowance can be given for improvements in forecasting, load estimation or structural analysis, as the technology or expertise in any one of these areas improves.

NOTE 2

The specific minimum yield point may be determined, for the use of D3, by the drop of the beam or halt in the gauge in the testing machine or by the use of dividers or by 0,5% total extension under load. When no well defined yield phenomenon exists, the yield strength associated with a 0,2% offset or a 0,5% total extension under load is to be considered the yield strength.

D3.6 Units resting on the sea bed

D3.6.1 Units designed to rest on the sea bed are to have sufficient positive downward gravity loadings on the support footings or mat to withstand the overturning moment of the combined environmental forces from any direction, with a reserve against the loss of positive bearing of any footing or segment of the area thereof, for each design loading condition. Variable loads are to be considered in a realistic manner, to the satisfaction of the Society.

D3.7 Stability**D3.7.1 General**

All units are to have positive stability in calm water equilibrium position, for the full range of draughts when in all modes of operation afloat, and for temporary positions when raising or lowering. In addition, all units are to meet the stability requirements set forth herein for all applicable conditions.

D3.7.2 Intact stability

All units are to have sufficient stability (righting ability) to withstand the overturning effect of the force produced by a sustained wind from any horizontal direction, in accordance with the stability criteria given in D3.8, for all afloat modes of operation. Realistic operating conditions are to be evaluated, and the unit should be capable of remaining in the operating mode with a sustained wind velocity of not less than 36 m/s (70 knots). The capability is to be provided to change the mode of operation of the unit to that corresponding to a severe storm condition, with a sustained wind velocity of not less than 51,5 m/s (100 knots), in a reasonable period of

D3 (cont)

time for the particular unit. In all cases, the limiting wind velocities are to be specified and instructions should be included in the Operating Booklet for changing the mode of operation by redistribution of the variable load and equipment, by changing draughts, or both. For restricted operations consideration may be given to a reduced sustained wind velocity of not less than 25,8 m/s (50 knots). Particulars of the applicable service restrictions should be recorded in the Operating Booklet. For the purpose of calculation it is to be assumed that the unit is floating free of mooring restraints. However, the possible detrimental effects of mooring restraints are to be considered.

D3.7.3 Damage stability

- (1) All units are to have sufficient stability to withstand the flooding from the sea of any single compartment or any combination of compartments consistent with the damage assumption set out in D4.4.1, D5.6.1 and D6.4.1, for operating and transit modes of operation. The unit is to possess sufficient reserve stability in the damaged condition to withstand the additional heeling moment of a 25,8 m/s (50 knots) sustained wind superimposed from any direction.
- (2) Additionally, column stabilized units are to have sufficient stability to withstand, in any operating or transit condition with the assumption of no wind, the flooding of any single watertight compartment located wholly or partially below the waterline in question, which is a pump room, a room containing machinery with a salt water cooling system or a compartment adjacent to the sea.
- (3) For all types of units, the ability to compensate for damage incurred, by pumping out or by ballasting other compartments, etc., is not to be considered as alleviating the above requirements. For the purpose of calculation, it is to be assumed that the unit is floating free of mooring restraints. However, possible detrimental effects of mooring restraints are to be considered.

D3.7.4 Light ship weight and centre of gravity

An inclining test will be required for the first unit of a design when as near to completion as possible, to determine accurately the light ship weight and position of centre of gravity. An inclining test procedure is to be submitted to the Society for review prior to the test, which is to be witnessed by a Surveyor of the Society. For successive units of a design, which are basically identical with regard to hull form, with the exception of minor changes in arrangement, machinery, equipment, etc., and with concurrence by the Society that such changes are minor, detailed weight calculations showing only the differences of weight and centres of gravity will be satisfactory, provided the accuracy of the calculations is confirmed by a deadweight survey. The results of the inclining test, or deadweight survey and inclining experiment adjusted for weight differences, should be reviewed by the Society prior to inclusion in the Operating Booklet.

D3.8 Stability criterion under wind force

D3.8.1 Intact condition

Righting moment curves and wind heeling moment curves related to the most critical axis, with supporting calculations, are to be prepared for a sufficient number of conditions covering the full range of draughts corresponding to afloat modes of operation (cf. Fig. 1). Where drilling equipment is of the nature that it can be lowered and stowed, additional wind heeling moment and stability curves may be required, and such data should clearly indicate the position of such equipment. In all cases, except column stabilized units, the area under the righting moment curve to the second intercept or downflooding angle, whichever is less, is not

D3 (cont)

to be less than 40% in excess of the area under the wind heeling moment curve to the same limiting angle. For column stabilized units, the area under the righting moment curve to the angle of downflooding is not to be less than 30% in excess of the area under the wind heeling moment curve to the same limiting angle. In all cases, the righting moment curve is to be positive over the entire range of angles from upright to the second intercept.

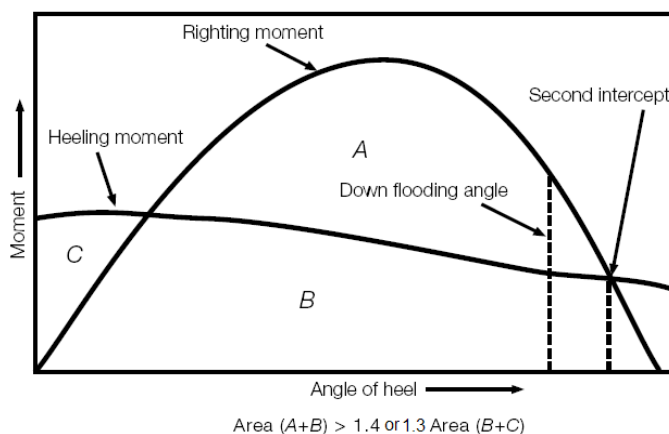

Fig.1 Righting moment and heeling moment curves

D3.8.2 Wind heeling moment

The wind heeling moment is to be calculated at several angles of inclination for each mode of operation. The calculations should be performed in a manner to reflect the range of stability about the most critical axis. The lever for the heeling force should be taken vertically from the centre of lateral resistance or, if available, the centre of hydrodynamic pressure, of the underwater body to the centre of pressure of the areas subject to wind loading. In calculating wind heeling moments for shipshaped hulls, the curve may be assumed to vary as the cosine function of the vessel's heel.

Wind heeling moments should be based on wind forces calculated by the following formula:

$$F = 0,5_p C_s C_h A V^2$$

where

F = the wind force (N)

p = the air mass density (1.222 kg/m³)

C_s = the shape coefficient

C_h = the height coefficient

A = the projected area of all exposed surfaces in either the upright or the heeled condition (m²)

v = the wind velocity (m/s)

NOTE: All units are to be consistent.

D3 (cont)

- (i) The values of the coefficient C_s depend on the shape of the wind-exposed area and should be based on the following:

Shape	C_s
Spherical	0.4
Cylindrical	0.5
Large flat surface (hull, deckhouse, smooth under-deck areas)	1.0
Drilling derrick	1.25
Wires	1.2
Exposed beams and girders under deck	1.3
Small parts	1.4
Isolated shapes (crane, beam, etc.)	1.5
Clustered deckhouses or similar structures	1.1

Shapes or combinations of shapes which do not readily fall into the specified categories will be subject to special consideration by the Society.

- (ii) The values of the coefficient C_h depend on the height of the centre of the wind exposed area sea level and are given below:

Height				C_h
Metres		Feet		
Over	Not Exceeding	Over	Not Exceeding	
0	15,3	0	50	1,0
15,3	30,3	50	100	1,10
30,5	46,0	100	150	1,20
46,0	61,0	150	200	1,30
61,0	76,0	200	250	1,37
76,0	91,5	250	300	1,43
91,5	106,5	300	350	1,48
106,5	122,0	350	400	1,52
122,0	137,0	400	450	1,56
137,0	152,5	450	500	1,60
152,5	167,5	500	550	1,63
167,5	183,0	550	600	1,67
183,0	198,0	600	650	1,70
198,0	213,5	650	700	1,72
213,5	228,5	700	750	1,75
228,5	244,0	750	800	1,77
244,0	259,0	800	850	1,79
above 259		above 850		1,80

- (iii) In calculating the wind forces, the following procedures are recommended:

(a) In the case of units with columns, the projected areas of all columns should be included; i.e. no shielding allowance should be taken.

(b) Areas exposed due to heel, such as underdecks, etc., should be included using the appropriate shape coefficients.

(c) The block projected area of a clustering of deckhouses may be used in lieu of calculating each individual area. The shape coefficient may be assumed to be 1,1.

D3 (cont)

(d) Isolated houses, structural shapes, cranes, etc., should be calculated individually, using the appropriate shape coefficient.

(e) Open truss work commonly used for derrick towers, booms and certain types of masts may be approximated by taking 30% of the projected block area of each side, e.g. 60% of the projected block area of one side for double-sided truss work. An appropriate shape coefficient is to be taken from the table.

D3.8.3 Damage conditions

- (1) Self elevating and surface type units are to have sufficient stability per D3.7.3(1), such that the final waterline is located below the lower edge of any opening that does not meet the watertight integrity requirements of D7.4.2.

For self-elevating units particularly, the flooding of any single compartment with the assumption of no wind while meeting the following criterion:

$$RoS = \theta_m - \theta_s \geq \text{Max} \left\{ (7^\circ + 1.5\theta_s) , 10^\circ \right\}$$

where:

RoS = range of stability, in degrees

θ_m = maximum angle of positive stability, in degrees

θ_s = static angle of inclination after damage, in degrees

The range of stability is determined without reference to the angle of downflooding. Refer to Fig.2.

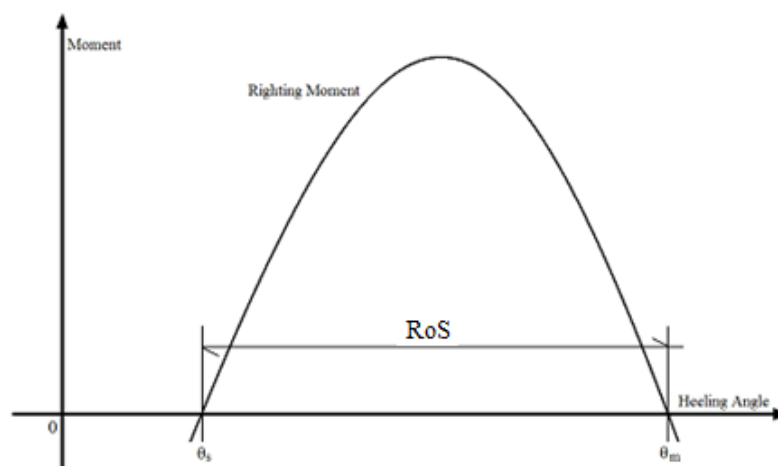

Fig.2 Residual stability for self-elevating units

- (2) Column stabilized units are to have sufficient stability per D3.7.3(1) such that:

(a) the final waterline is located below the lower edge of any opening that does not meet the watertight integrity requirements of D7.4.2 (Attention is drawn to 3.4.3 of the 2009 IMO MODU Code [Res A.1023(26)] which limits the inclination of the unit relative to this final waterline, to be not greater than 17 degrees. Refer to Fig.3. Compliance with this limitation may be required by some Administrations).

D3 (cont)

(b) within the provided extent of weathertight integrity the damage righting moment curve is to have a range of at least 7 degrees beyond its first intercept with the 25,8 m/sec (50 knots) wind heeling moment curve to its second intercept or downflooding angle, whichever is less. Further, the damage righting moment curve is to reach a value of at least twice the wind heeling moment curve, both measured at the same angle. Refer to Fig.3.

(c) openings within 4 m above the final waterline are to be made weathertight.

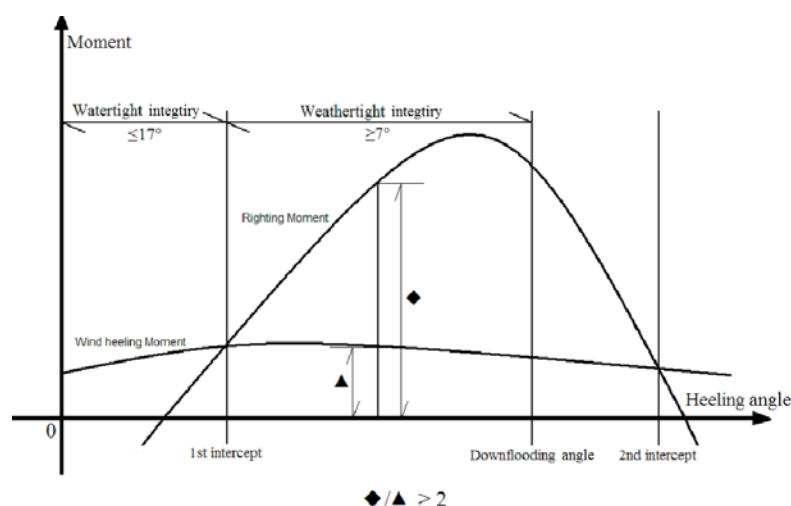

Fig.3 Residual damage stability requirements for column stabilized units

(3) Column stabilized units are to have sufficient stability per D3.7.3(2) such that:

(a) the equilibrium waterline is located below the lower edge of any opening that does not meet the watertight integrity requirements of D7.4.2 (Attention is drawn to 3.4.4 of the 2009 IMO MODU Code [Res A.1023(26)] which limits the inclination of the unit, relative to this equilibrium waterline, to be not greater than 25 degrees. Compliance with this limitation may be required by some Administrations).

(b) sufficient margin of stability is provided. (Attention is drawn to 3.4.4 of the 2009 IMO MODU Code [Res A.1023(26)] which requires a range of positive stability of at least 7 degrees beyond the first intercept of the righting moment curve and the horizontal coordinate axis of the static stability curve to the second intercept of them or the downflooding angle, whichever is less. Compliance with this range may be required by some Administrations).

D3.8.4 Wind tunnel tests

Wind heeling moments derived from authoritative wind tunnel tests on a representative model of the unit may be considered as alternatives to the method given herein. Such heeling moment determination is to include lift effects at various applicable heel angles, as well as drag effects.

D3.8.5 Other Stability Criteria

(1) Alternative stability criteria may be considered acceptable provided the criteria afford adequate righting moment to resist the heeling effects of operating and environmental forces and sufficient margins to preclude downflooding and capsizing in intact and damaged conditions.

D3
(cont)

- (2) The following will be considered in determining the adequacy of alternative criteria submitted for review:
- (a) Environmental conditions representing realistic winds (including gusts) and waves appropriate for various modes of operations;
 - (b) Dynamic response of a unit. Where appropriate, the analysis should include the results of wind tunnel tests, wave tank model tests and nonlinear simulation. Any wind and wave spectra used should cover sufficient frequency ranges to ensure that critical motion responses are obtained;
 - (c) Potential for downflooding, taking into account dynamic responses and wave profile;
 - (d) Susceptibility to capsizing considering the unit's restoration energy, static inclination due to mean wind speed and maximum dynamic responses;
 - (e) A safety margin consistent with the methodology to account for uncertainties;
 - (f) Damage assumptions at least equivalent to the requirements contained in Sections D4.4.1, D5.6.1 and D6.4.1;
 - (g) For column stabilized units one compartment flooding assumptions at least equivalent to the requirement contained in D3.7.3(2).

D3.9 Load line

D3.9.1 Any unit to which a load line is required to be assigned under the applicable terms of the International Convention on Load Lines should be subject to compliance with the Convention. All other units are to have load line marks which designate the maximum permissible draught when the unit is in the afloat condition. Such markings are to be placed at suitable visible locations on the structure, to the satisfaction of the Society. These marks, where practicable, are to be visible to the person in charge of mooring, lowering or otherwise operating the unit. The permissible draughts are to be established on the basis of meeting the applicable stability and structural requirements as set forth herein for afloat modes of operation, with such seasonal allowances as may be determined. In no case is the draught to exceed that permitted by the International Convention on Load Lines, where applicable. A load line, where assigned, is not applicable to bottom-supported units when resting on the sea bed, or when lowering to or raising from such position.

D3.9.2 Self Elevating and Surface Units – Moonpools

1. Where moonpools are arranged within the hull in open communication with the sea, the volume of the moonpool should not be included in calculation of any hydrostatic properties. An addition should be made to the geometric freeboard if the moonpool has a larger cross-sectional area above the waterline at 85% of the depth for freeboard (depth for freeboard has the same meaning as defined in regulation 3 of the 1988 LL Protocol) than below, corresponding to the lost buoyancy. This addition for the excess portion above the 85% of the depth for freeboard waterline should be made as prescribed below for wells/recesses. If an enclosed superstructure contains part of the moonpool, deduction should be made for the effective length of the superstructure.

Where open wells/recesses are arranged in the freeboard deck, a correction equal to the volume of the well/recess to the freeboard deck divided by the waterplane area at 85% of the depth for freeboard should be added to the freeboard obtained after all other

D3
(cont)

corrections have been applied, except bow height correction. Free surface effects of the flooded well/recess should be taken into account in stability calculations.

2. The procedure described in D3.9.2.1 should also apply in cases of small notches or relatively narrow cut-outs at the stern of the unit.
3. Narrow wing extensions at the stern of the unit should be considered as appendages and excluded for the determination of length (L) and for the calculation of freeboards. The Society should determine the effect of such wind extensions with regard to the requirements for the strength of the unit based upon length(L).

Note: Self-elevating units: The minimum freeboard of self elevating units which due to their configuration cannot be computed by the normal methods laid down by the Load Line Convention should be determined on the basis of meeting applicable intact stability, damage stability and structural requirements in the afloat condition.

D3.9.3 Column Stabilized Units

1. The hull form of column stabilized units makes the calculations of geometric freeboard in accordance with the provisions of the Load Line Convention impracticable. Therefore, the minimum freeboard of each column stabilized unit should be determined by meeting the applicable requirements for:
 - a) the strength of unit's structure
 - b) the minimum clearance between passing wave crests and deck structure and
 - c) intact and damage stability requirements.
2. The enclosed deck structure of each column stabilized unit should be specially considered by the Society for each unit.
3. Societies should also give special consideration to the position of openings which cannot be closed in emergencies, such as air intakes for emergency generators having regard to the intact righting arm curves and the final waterline after assumed damage.

D3.10 Helicopter deck**D3.10.1 General**

Plans showing the arrangement, scantlings and details of the helicopter deck are to be submitted. The arrangement plan is to show the overall size of the helicopter deck and the designated landing area. If the arrangement provides for the securing of a helicopter or helicopters to the deck, the predetermined position(s) selected to accommodate the secured helicopter, in addition to the locations of deck fittings for securing the helicopter, are to be shown. The helicopter for which the deck is designed is to be specified, and calculations for the relevant loading conditions are to be submitted. The identification of the helicopter which is used for design purposes should be included in the Operating Booklet.

D3.10.2 Structural design

Scantlings of helicopter decks and supporting structure are to be determined on the basis of the following design loading conditions in association with the allowable stresses shown in Table 1.

- (i) Overall distributed loading: A minimum distributed loading of 2 kN/m² (42 lb/ft²) is to be taken over the entire helicopter deck.

D3 (cont)

(ii) Helicopter landing impact loading: A load of not less than 75% of the helicopter maximum take-off weight is to be taken on each of two square areas, 0,3 m x 0,3 m (1 ft x 1 ft). The deck is to be designed for helicopter landings at any location within the designated area. For the design of girders, stanchions truss supports, etc., the structural weight of the helicopter deck should be considered in addition to the helicopter impact loading. Where the upper deck of a superstructure or deckhouse is used as a helicopter deck and the spaces below are normally manned (quarters, bridge, control room, etc.) the impact loading is to be multiplied by a factor of 1,15.

(iii) Stowed helicopter loading: If provisions are made to accommodate helicopters secured to the deck in a predetermined position, the structure is to be designed for a local loading equal to the manufacturer's recommended wheel loadings at maximum take-off weight, multiplied by a dynamic amplification factor based on the predicted motions of the unit for this condition, as may be applicable for the unit under consideration. In addition, a uniformly distributed loading of 0,5 kN/m² (10,5 lb/ft²), representing wet snow or ice, is to be considered, if applicable. For the design of girders, stanchions, truss supports, etc., the structural weight of the helicopter deck should also be considered.

Table 1 Allowable stresses

Condition	Allowable stress		
	Plating	Beams	Girders, stanchions, truss supports, etc.
1. Overall distributed loading	0,6 σ_Y (See Note 1)	0,6 σ_Y	0,6 σ_Y^*
2. Helicopter landing impact loading	**	σ_Y	0,9 σ_Y^*
3. Stowed helicopter loading	σ_Y	0,9 σ_Y	0,8 σ_Y^*
σ_Y = specified minimum tensile yield strength of the material			
* For members subjected to axial compression, the yield stress or critical buckling stress, whichever is less, is to be considered.			
** To the satisfaction of the Society, in association with the method of analysis presented. The Society may consider an allowable stress that exceeds σ_Y , provided the rationale of the analysis is sufficiently conservative.			
NOTES			
1. The thickness of plating for the overall distributed loading condition is not to be less than the minimum required by the Rules.			
2. Helicopters fitted with landing gear other than wheels shall be specially considered by the Society.			
3. Wind loadings and possible wave impact loadings on helicopter decks are to be considered in a realistic manner, to the satisfaction of the Society.			

D3.11 Position keeping systems and components

D3.11.1 General

D3.11.1.1 Units provided with position keeping systems equipment in accordance with D3.11 will be eligible to have a special optional notation included in the classification designation in accordance with the policy of the Society.

D3 (cont)

D3.11.2 Anchoring Systems

D3.11.2.1 General

Plans showing the arrangement and complete details of the anchoring system, including anchors, shackles, anchor lines consisting of chain, wire or rope, together with details of fairleads, windlasses, winches, and any other components of the anchoring system and their foundations are to be submitted to the Society.

D3.11.2 .2 Design

D3.11.2.2.1 An analysis of the anchoring arrangements expected to be utilized in the unit's operation is to be submitted to the Society. Among the items to be addressed are:

1. Design environmental conditions of waves, winds, currents, tides and ranges of water depth.
2. Air and sea temperature.
3. Ice conditions (if applicable).
4. Description of analysis methodology.

D3.11.2.2.2 The anchoring system should be designed so that a sudden failure of any single anchor line will not cause progressive failure of remaining lines in the anchoring arrangement.

D3.11.2.2.3 Anchoring system components should be designed utilizing adequate factors of safety (FOS) and a design methodology suitable to identify the most severe loading condition for each component. In particular, sufficient numbers of heading angles together with the most severe combination of wind, current and wave are to be considered, usually from the same direction, to determine the maximum tension in each mooring line. When a particular site is being considered, any applicable cross sea conditions are also to be considered in the event that they might induce higher mooring loads.

D3.11.2.2.3.1 When the Quasi Static Method is applied, the tension in each anchor line is to be calculated at the maximum excursion for each design condition defined in D3.11.2.2.3.2, combining the following steady state and dynamic responses of the Unit:

- (a) steady mean offset due to the defined wind, current, and steady wave forces;
- (b) most probable maximum wave induced motions of the moored unit due to wave excitation.

For relatively deep water, the effect from damping and inertia forces in the anchor lines is to be considered in the analysis. The effects of slowly varying motions are to be included for MODUs when the magnitudes of such motions are considered to be significant.

D3.11.2.2.3.2 When the Quasi Static Method outlined in D3.11.2.2.3.1 is applied, the following minimum factors of safety at the maximum excursion of the unit for a range of headings should be considered:

DESIGN CONDITION	FOS
Operating	2,7
Severe storm	1,8
Operating – one line failed	1,8
Severe storm – one line failed	1,25

D3 (cont)

where:

$$FOS = PB/T_{max}$$

T_{max} = characteristic tension in the anchor line, equal to the maximum value obtained according to D3.11.2.2.3.1

PB = minimum rated breaking strength of the anchor line

Operating: the most severe design environmental condition for normal operations as defined by the owner or designer

Severe storm: the most severe design environmental condition for severe storm as defined by the owner or designer

Operating –
one line failed: following the failure of any one mooring line in the operating condition

Severe storm –
one line failed: following the failure of any one mooring line in the severe storm condition
When a dynamic analysis is employed, other safety factors may be considered to the satisfaction of the Society.

The defined Operating and Severe Storm are to be the same as those identified for the design of the unit, unless the Society is satisfied that lesser conditions may be applicable to specific sites.

D3.11.2.2.3.3 In general, the maximum wave induced motions of the moored unit about the steady mean offset should be obtained by means of model tests. The Society may accept analytical calculations provided that the proposed method is based on a sound methodology which has been validated by model tests.

In the consideration of column stabilized MODUs, the value of C_s and C_H , as indicated in D3.8.2, may be introduced in the analysis for position keeping mooring systems. The intent of D3.8.3 – Wind tunnel tests, and of D3.8.4 – Other stability requirements, may also be considered by the Society.

D3.11.2.2.3.4 The Society may accept different analysis methodologies provided that it is satisfied that a level of safety equivalent to the one obtained by D3.11.2.2.3.1 and D3.11.2.2.3.2 is ensured.

D3.11.2.2.3.5 The Society may give special consideration to an arrangement where the anchoring systems are used in conjunction with thrusters to maintain the unit on station.

D3.11.3 Equipment

D3.11.3.1 Windlasses

D3.11.3.1.1 The design of the windlass is to provide for adequate dynamic braking capacity to control normal combinations of loads from the anchor, anchor line and anchor handling vessel during the deployment of the anchors at the maximum design payout speed of the windlass. The attachment of the windlass to the hull structure is to be designed to withstand the breaking strength of the anchor line.

D3
(cont)

D3.11.3.1.2 Each windlass is to be provided with two independent power operated brakes and each brake is to be capable of holding against a static load in the anchor lines of at least 50 percent of its breaking strength. Where the Society so allows, one of the brakes may be replaced by a manually operated brake.

D3.11.3.1.3 On loss of power to the windlasses, the power operated braking system should be automatically applied and be capable of holding against 50 percent of the total static braking capacity of the windlass.

D3.11.3.2 Fairleads and Sheaves

D3.11.3.2.1 Fairleads and sheaves should be designed to prevent excessive bending and wear of the anchor lines. The attachments to the hull or structure are to be such as to withstand the stresses imposed when an anchor line is loaded to its breaking strength.

D3.11.4 Anchor line

D3.11.4.1 The Society is to be ensured that the anchor lines are of a type that will satisfy the design conditions of the anchoring system.

D3.11.4.2 Means are to be provided to enable the anchor lines to be released from the unit after loss of main power.

D3.11.4.3 Means are to be provided for measuring anchor line tensions.

D3.11.4.4 Anchor lines are to be of adequate length to prevent uplift of the anchors under the maximum design condition for the anticipated area(s) of operation.

D3.11.5 Anchors

D3.11.5.1 Type and design of anchors are to be to the satisfaction of the Society.

D3.11.5.2 All anchors are to be stowed to prevent movement during transit.

D3.11.6 Quality Control

D3.11.6.1 Details of the quality control of the manufacturing process of the individual anchoring system components are to be submitted. Components should be designed, manufactured and tested in accordance with recognized standards insofar as possible and practical. Equipment so tested should, insofar as practical, be legibly and permanently marked with the Society's stamp and delivered with documentation which records the results of the tests.

D3.11.7 Control Stations

D3.11.7.1 A manned control station is to be provided with means to indicate anchor line tensions at the individual windlass control positions and to indicate wind speed and direction.

D3.11.7.2 Reliable means are to be provided to communicate between locations critical to the anchoring operation.

D3.11.7.3 Means are to be provided at the individual windlass control positions to monitor anchor line tension, windlass power load and to indicate amount of anchor line payed out.

D3
(cont)

D3.11.8 Dynamic Positioning Systems

D3.11.8.1 Thrusters used as a sole means of position keeping should provide a level of safety equivalent to that provided for anchoring arrangements to the satisfaction of the Society.

End of Document

D4 Self-elevating drilling units

(1979)
(Rev.1
1990)
(Rev.2
1996)
(Rev.3
Jan
2012)

D4.1 General

D4.1.1 This section applies to the unit type as defined in D2.2.1.

D4.2 Hull scantlings

D4.2.1 Scantlings of the hull structure, except as outlined below, are to meet the Rules.

D4.3 Design considerations

D4.3.1 Legs

- (a) Leg types: Legs may be either shell type or truss type. Shell type legs may be designed as either stiffened or unstiffened shells. In addition, individual footings may be fitted or legs may be permanently attached to a bottom mat.
- (b) Legs without mats: Where footings or mats are not fitted, proper consideration should be given to the leg penetration of the sea bed and the end fixity of the leg.
- (c) Legs in the field transit condition: Legs are to be designed for a bending moment caused by a 6° single amplitude of roll or pitch at the natural period of the unit, plus 120% of the gravity moment caused by the legs' angle of inclination. The legs are to be investigated for any proposed leg arrangement with respect to vertical position during field transit moves, and the approved positions should be specified in the Operating Booklet. Such investigation should include strength and stability aspects.
- (d) Legs in the ocean transit condition: Legs should be designed for acceleration and gravity moments resulting from the motions in the most severe anticipated environmental transit conditions, together with corresponding wind moments. Calculation or model test methods, acceptable to the Society, may be used. Alternatively, legs may be designed for a bending moment caused by minimum design criteria of a 15° single amplitude of roll or pitch at a 10 second period, plus 120% of the gravity moment caused by the legs' angle of inclination. For ocean transit conditions, it may be necessary to reinforce or support the legs, or to remove sections of them. The approved condition should be included in the Operating Booklet.
- (e) Unit in the elevated position: When computing leg stresses, the maximum overturning load on the unit, using the most adverse combination of applicable variable loadings together with the loadings as outlined in D3, is to be considered. Forces and moments due to lateral frame deflections of the legs are to be taken into account. (See D3.3.3.(c) with respect to vibration).
- (f) Leg scantlings: Leg scantlings are to be determined in accordance with a method of rational analysis, to the satisfaction of the Society.

Notes:

1. This UR apply to mobile offshore drilling units contracted for construction on and after 1 January 2013.
2. The "contracted for construction" date means the date on which the contract to build the vessel is signed between the prospective owner and the shipbuilder. For further details regarding the date of "contract for construction", refer to IACS Procedural Requirement (PR) No. 29.

D4
(cont)

D4.3.2 Structure in way of jacking or other elevating arrangements

Load carrying members which transmit loads from the legs to the hull are to be designed for the maximum design loads and are to be so arranged that loads transmitted from the legs are properly diffused into the hull structure.

D4.3.3 Hull structure

The hull is to be considered as a complete structure having sufficient strength to resist all induced stresses while in the elevated position and supported by all legs. All fixed and variable loads are to be distributed, by an accepted method of rational analysis, from the various points of application to the supporting legs. The scantlings of the hull are then to be determined consistent with this load distribution, but are not to be less than those required by D4.2. Scantlings of units having other than rectangular hull configurations will be subject to special consideration.

D4.3.4 Wave clearance

The unit is to be designed for a crest clearance of either 1,2 m (4 ft), or 10% of the combined storm tide, astronomical tide and height of the maximum wave crest above the mean low water level, whichever is less, between the underside of the unit in the elevated position and the crest of the design wave. This crest elevation is to be measured above the level of the combined astronomical and storm tides.

D4.3.5 Bottom mat

When the bottoms of the legs are attached to a mat, particular attention is to be given to the attachment and the framing and bracing of the mat, in order that the loads resulting from the legs are properly distributed. The envelope plating of tanks which are not vented freely to the sea is not to be less in thickness than would be required by the Rules for tanks, using a head to the design water level, taking into account the astronomical and storm tides. The effects of scouring on the bottom bearing surface should be considered. The effects of skirt plates, where provided, will be specially considered. Mats are to be designed to withstand the shock of touching bottom while the unit is afloat and subject to wave motions.

D4.3.6 Preload capability

For units without bottom mats, all legs are to have the capability of being preloaded to the maximum applicable combined gravity plus overturning load. The approved preload procedure should be included in the Operating Booklet.

D4.3.7 Sea bed conditions

Classification will be based upon the designer's assumptions regarding the sea bed conditions. These assumptions should be recorded in the Operating Booklet. It is the responsibility of the operator to ensure that actual conditions do not impose more severe loadings on the unit.

D4.3.8 Deckhouses

Deckhouses are to have sufficient strength for their size, function and location, and are to be constructed to approved plans. Their general scantlings are to be as indicated in the Rules. Where they are close to the side shell of the unit, their scantlings may be required to conform to the Society's requirements for bulkheads of unprotected house fronts.

D4
(cont)**D4.4 Damage stability**

D4.4.1 In assessing the damage stability of self-elevating drilling units as required by D3.7.3, the following extent of damage is to be assumed to occur between effective watertight bulkheads:

- (i) Horizontal penetration: 1,5 m (5 ft).
- (ii) Vertical extent: bottom shell upwards without limit.
The distance between effective watertight bulkheads or their nearest stepped portions which are positioned within the assumed extent of horizontal penetration should be not less than 3 m; where there is a lesser distance, one or more of the adjacent bulkheads should be disregarded.
Where a bottom mat is fitted, assumed damage penetration simultaneous to both the mat and the upper hull need only be considered when the lightest draught allows any part of the mat to fall within 1,5 m (5 ft) vertically of the waterline, and the difference in horizontal dimension of the upper hull and mat is less than 1,5 m (5 ft) in any area under consideration. If damage of a lesser extent results in a more severe final equilibrium condition, such lesser extent shall be assumed.
All piping, ventilating systems, trunks, etc., within this extent are to be assumed damaged. Positive means of closure are to be provided to preclude progressive flooding of other intact spaces. In addition, the compartments adjacent to the bottom shell are also to be considered flooded individually.

The recessed ends and sides of the drilling slot need not be subject to horizontal penetration if warning signs be posted on each side of the vessel stating that no boats be allowed inside the drilling slot. Instructions to this effect should be included in the Operating Booklet.

D4**(cont)****Annex to UR D4 as Recommendations on Operation of Legs:**

- (1) Legs while lowering to bottom: Legs are to be designed to withstand the dynamic loads which may be encountered by their unsupported length just prior to touching bottom, and also to withstand the shock of touching bottom while the unit is afloat and subject to wave motions.
- (2) Instructions for lowering legs: The maximum design motions, bottom conditions and sea state while lowering legs should be clearly indicated in the Operating Booklet, and the legs are not to be permitted to touch bottom when the site conditions exceed the allowable.

End of Document

D5

1979)
(Rev. 1
1987)
(Rev. 2
1990)
(Rev. 3
1996)

Column stabilized drilling units

D5.1 General

D5.1.1 This section applies to the unit type as defined in D2.2.2

D5.1.2 For units of this type, the highest stresses may be associated with less severe environmental conditions than the maxima specified by the owner (designer). Where considered necessary by the Society, account should be taken of the consequent increased possibility of encounter of significant stress levels, by either or both of the following:

- (i) Suitable reduction of the allowable stress levels for combined loadings given in D3.
- (ii) Detailed investigation of the fatigue properties.

Particular attention should also be given to the details of structural design in critical areas such as bracing members, joint connections, etc.

D5.1.3 Local structures in way of fairleads, winches, etc., forming part of the position mooring system, should be designed to the breaking strength of the mooring line.

D5.2 Upper structure

D5.2.1 The scantlings of the upper structure are not to be less than those required by the Rules in association with the loadings indicated on the deck loading plan. (These loadings are not to be less than the minima specified in D3.3.6) In addition, when the upper structure is considered to be an effective member of the overall structural frame of the unit, the scantlings are to be sufficient to withstand actual local loadings plus any additional loadings superimposed due to frame action, within the stress limitations of D3.

D5.2.2 When the upper structure is designed to be waterborne in any mode of operation or damaged condition, or to meet stability requirements, it will be subject to special consideration.

D5.2.3 Deckhouses fitted to the upper structure are to be designed in accordance with the Rules, with due consideration given to their location and to the environmental conditions in which the unit will operate.

D5.3 Columns, lower hulls and footings

D5.3.1 Main stability columns, lower hulls or footings may be designed as either framed or unframed shells. In either case, framing, ring stiffeners, bulkheads or other suitable diaphragms which are used are to be sufficient to maintain shape and stiffness under all the anticipated loadings.

Portlights or windows including those of the non-opening type, or other similar openings, are not to be fitted in columns.



D5.3.2

- (a) Where columns, lower hulls or footings are designed with stiffened plating, the minimum scantlings of plating, framing, girders, etc., may be determined in accordance with the requirements for tanks as given in D7. Where an internal space is a void compartment, the design head used in association with the above is not to be less than that corresponding to the maximum allowable waterline of the unit in service. In general, the scantlings are not to be less than required for watertight bulkheads in association with a head equivalent to the maximum damaged waterline, and for all areas subject to wave immersion, a minimum head of 6,0 m (20 ft) should be used.
- (b) Where columns, lower hulls or footings are designed as shells, either unstiffened or ring stiffened, the minimum scantlings of shell plating and ring stiffeners are to be determined on the basis of established shell analysis using the appropriate usage factors and the design heads as given in (a).
- (c) Scantlings of columns, lower hulls or footings as determined in (a) and (b) are minimum requirements for hydrostatic pressure loads. Where wave and current forces are superimposed, the local structure of the shell is to be increased in scantlings as necessary, to meet the strength requirements of D3.4.1 (ii).
- (d) When the column, lower hull or footing is an effective member of the overall structural frame of the unit, the scantlings are to be sufficient to meet the requirements of D5.3 plus any additional stresses superimposed due to frame action, within the stress limitations of D3.
- (e) Particular consideration is to be given to structural details, reinforcement, etc., in areas subject to high local loadings, or to such loadings that may cause shell distortion; for example:
 - (i) bottom bearing loads, where applicable;
 - (ii) partially filled tanks;
 - (iii) local strength against external damage;
 - (iv) continuity through joints;
 - (v) wave impacts.
- (f) For units designed to rest on the sea bed, the effect of scouring action (loss of bottom support) is to be considered. The effects of skirt plates, where provided, will be specially considered.

D5.3.3 Bracing members

- (a) Stresses in bracing members due to all anticipated loadings are to be determined in accordance with the following requirements in conjunction with the relevant requirements of D3.
- (b) Bracing members are to be designed to transmit loadings and to make the structure effective against environmental forces and, when the unit is supported by the seabed, against the possibility of uneven bearing loads. Although designed primarily as brace members of the overall structure under the designated loadings, the bracing must also be investigated, if applicable, for superimposed local bending stresses due to buoyancy, wave and current forces.
- (c) Where relevant, consideration is to be given to local stresses due to wave impact.
- (d) When bracing members are of tubular section, ring frames may be required to maintain stiffness and roundness of shape.
- (e) When bracings are watertight, they are to be suitably designed to prevent collapse from external hydrostatic pressure.



D5

cont'd

D5.4 Wave clearance

D5.4.1 Afloat condition

Unless deck structures are designed for wave impact, to the satisfaction of the Society, reasonable clearance between the deck structures and the wave crests is to be ensured for all afloat modes of operation, taking into account the predicted motion of the unit relative to the surface of the sea. Calculations, model test results, or prototype experiences are to be submitted for consideration.

D5.4.2 On-bottom condition

For on-bottom modes of operation, clearances are to be in accordance with those specified in D4.3.4 for self-elevating units.

D5.5 Structural Redundancy

D5.5.1 When assessing structural redundancy for column stabilized units, the following assumed damage conditions shall apply:

1. The unit's structure shall be able to withstand the loss of any slender bracing member without causing overall collapse of the unit's structure.
2. Structural redundancy will be based on the applicable requirements of D3.3, D3.4, D3.5, and D3.6, except:
 - a. Maximum calculated stresses in the structure remaining after the loss of a slender bracing member are to be in accordance with D3.5 in association with usage factors not exceeding 1.0. This criteria may be exceeded for local areas, provided redistribution of forces due to yielding or buckling is taken into consideration.
 - b. When considering environmental factors, a one year return period may be assumed for intended areas of operations. (see D3.3.1)

D5.5.2 The structural arrangement of the upper hull is to be considered with regard to the structural integrity of the unit after the failure of any primary girder.

D5.6 Damage Stability

D5.6.1 In assessing the damage stability of column stabilized drilling units as required by D3.7.3, the following assumed damage conditions apply.

- (1) Only those columns, underwater hulls and braces on the periphery of the unit should be assumed to be damaged and the damage should be assumed in the exposed portions of the columns, underwater hulls and braces.
- (2) Columns and braces should be assumed to be flooded by damage having a vertical extent of 3.0 m occurring at any level between 5.0 m above and 3.0 m below the draughts specified in the Operating manual. Where a watertight flat is located within this region, the damage should be assumed to have occurred in both compartments above and below the watertight flat in question. Lesser distances above or below the draughts may be applied taking into account the actual operating conditions. However, the extent of required damage region should be at least 1.5 m above and below the draft in question.
- (3) No vertical bulkhead should be assumed to be damaged, except where bulkheads are spaced closer than a distance of one eighth of the column perimeter at the draught under consideration, measured at the periphery, in which case one or more of the bulkheads should be disregarded.
- (4) Horizontal penetration of damage should be assumed to be 1.5 m.
- (5) Underwater hulls or footings should be assumed to be damaged when operating in a transit condition in the same manner as indicated in D5.6.1 (1), (2), (4) and having regard to their shape, either D5.6.1 (3) or between effective watertight bulk-



D5
cont'd

- heads.
- (6) If damage of a lesser extent results in a more severe damage equilibrium condition, such a lesser extent shall be assumed.
- (7) All piping, ventilation systems, trunks, etc., within the extent of damage should be assumed to be damaged. Positive means of closure should be provided to preclude the progressive flooding of other spaces which are intended to be intact.



D6 Surface type drilling units

(1979)
(Rev.1
Jan
2012)

D6.1 General

D6.1.1 This section applies to the unit type as defined in D2.2.3.

D6.2 Ship type drilling units

D6.2.1 Scantlings of the hull structure are to meet the Rules. Special consideration is, however, to be given to items which may require some deviation or additions to the Rules, in particular the items indicated in D6.2.2 - D6.2.5.

D6.2.2 The required strength of the unit is to be maintained in way of the drilling well, and particular attention is to be paid to the transition of fore and aft members so as to maintain continuity of the longitudinal material. In addition, the plating of the well is to be suitably stiffened to prevent damage due to foreign objects which may become trapped in the well while the unit is under way.

D6.2.3 The deck area in way of large hatches is to be suitably compensated where necessary to maintain the strength of the unit.

D6.2.4 The structure in way of heavy concentrated loads resulting from the drilling derrick, pipe rack, set back, drilling mud storage, etc., is to be suitably reinforced.

D6.2.5 Local structure in way of fairleads, winches, etc., forming part of the position mooring system, should be designed to the breaking strength of the mooring line.

D6.3 Barge type drilling units

D6.3.1 Scantlings of the hull structure are to meet the Rules. Special consideration, where applicable, is to be given to items listed in D6.2.

D6.4 Damage stability

D6.4.1 Extent of damage

In assessing the damage stability of surface type drilling units as required by D3.7.3, the following extent of damage is to be assumed to occur between effective watertight bulkheads:

- (i) Horizontal penetration: 1.5 m (5 ft).
- (ii) Vertical extent: bottom shell upwards without limit.

Notes:

1. This UR apply to mobile offshore drilling units contracted for construction on and after 1 January 2013.
2. The "contracted for construction" date means the date on which the contract to build the vessel is signed between the prospective owner and the shipbuilder. For further details regarding the date of "contract for construction", refer to IACS Procedural Requirement (PR) No. 29.

D6
(cont)

The distance between effective watertight bulkheads or their nearest stepped portions which are positioned within the assumed extent of horizontal penetration should be not less than 3 m; where there is a lesser distance, one or more of the adjacent bulkheads should be disregarded.

If damage of a lesser extent results in a more severe final equilibrium condition, such lesser extent shall be assumed.

All piping, ventilating systems, trunks, etc., within this extent are to be assumed damaged. Positive means of closure are to be provided to preclude progressive flooding of other intact spaces. In addition, the compartments bounded by the bottom shell are to be considered flooded individually.

End of Document

D7 Watertight integrity

(1979)
(Rev.1
1990)
(Rev.2
1996)
(Rev.3
Jan
2012)

D7.1 Watertight boundaries

D7.1.1 All units are to be provided with watertight bulkheads as may be required by the Rules. In all cases, the plans submitted are to clearly indicate the location and extent of the bulkheads. In the case of column stabilized drilling units, the scantlings of the watertight flats and bulkheads are to be made effective to that point necessary to meet the requirements of damage stability and are to be indicated on the appropriate plans.

D7.1.2 All surface type units are to be fitted with a collision bulkhead as may be required by the Rules. Sluice valves, cocks, manholes, watertight doors, etc., are not to be fitted in the collision bulkhead. Elsewhere, watertight bulkheads are to be fitted as necessary to provide transverse strength and subdivision.

D7.2 Tank boundaries

D7.2.1 Tanks for fresh water or fuel oil, or any other tanks which are not intended to be kept entirely filled in service, are to have divisions or deep swashes as may be required to minimize the dynamic stress on the structure. Tight divisions and boundary bulkheads of all tanks are to be constructed in accordance with the Rules. The arrangement of all tanks, together with their intended service and the height of the overflow pipes, is to be clearly indicated on the plans submitted for approval. Consideration is to be given to the specific gravity of the liquid in the tank.

D7.2.2 Tanks are to be tested in accordance with the Rules.

D7.3 Boundary penetrations

D7.3.1 Where watertight boundaries are required for damage stability, they are to be made watertight throughout, including piping, ventilation, shafting, electrical penetrations, etc. For compliance with the requirements of damage stability, D3.7.3, where individual lines, ducts or piping systems serve more than one compartment or are within the extent of damage, satisfactory arrangements are to be provided to preclude the possibility of progressive flooding through the system to other spaces, in the event of damage.

D7.3.2 Piping systems and ventilation ducts designed to watertight standards of the type mentioned in D7.3.1 are to be provided with valves in each compartment served. These valves are to be capable of being remotely operated from the weather deck, pump room or other normally manned space. Valve position indicators are to be provided at the remote control stations.

D7.3.3 Non-watertight ventilation ducts as mentioned in D7.3.1 are to be provided with watertight valves at the subdivision boundaries and the valves are to be capable of being operated from a remote location, with position indicators on the weatherdeck, or in a normally manned space. For self-elevating units, ventilating systems which are not used during the transit operations may be secured by alternative methods, subject to special consideration.

Notes:

1. This UR apply to mobile offshore drilling units contracted for construction on and after 1 January 2013.
2. The "contracted for construction" date means the date on which the contract to build the vessel is signed between the prospective owner and the shipbuilder. For further details regarding the date of "contract for construction", refer to IACS Procedural Requirement (PR) No. 29.

D7
(cont)**D7.4 Closures**

D7.4.1 General

External closing appliances are to be as prescribed by applicable load line requirements. Special consideration will be given to openings in the upper deck of column stabilized units.

D7.4.2 General requirements related to watertight integrity.

- (1) External openings, such as air pipes (regardless of closing appliances), ventilators, ventilation intakes and outlets, non-watertight hatches and weathertight doors, which are used during operation of the unit while afloat, are not to submerge when the unit is inclined to the first intercept of the righting moment and wind heeling moment curves in any intact or damaged condition. Openings, such as side scuttles of the non-opening type, manholes and small hatches, which are fitted with appliances to ensure watertight integrity, may be submerged*. Such openings are not to be regarded as emergency exits. Where flooding of chain lockers or other buoyant volumes may occur, the openings to these spaces should be considered as downflooding points.

* Such openings are not allowed to be fitted in the column of stabilized units (See D5.3).

- (2) External openings fitted with appliances to ensure watertight integrity, which are kept permanently closed while afloat, are to comply with the requirements of D7.4.2 (4).
- (3) Internal openings fitted with appliances to ensure watertight integrity are to comply with the following:
 - (i) Doors and hatch covers which are used during the operation of the unit while afloat should be remotely controlled from the central ballast control station and should also be operable locally from each side. Open/shut indicators should be provided at the control station. In addition, remotely operated doors provided to ensure the watertight integrity of internal openings which are used while at sea are to be sliding watertight doors with audible alarm. The power, control and indicators are to be operable in the event of main power failure. Particular attention is to be paid to minimizing the effect of control system failure. Each power-operated sliding watertight door shall be provided with an individual hand-operated mechanism. It shall be possible to open and close the door by hand at the door itself from both sides.
 - (ii) Doors or hatch covers in self-elevating units, or doors placed above the deepest load line draft in column-stabilized and surface units, which are normally closed while the unit is afloat may be of the quick acting type and should be provided with an alarm system (e.g., light signals) showing personnel both locally and at the central ballast control station whether the doors or hatch covers in question are open or closed. A notice should be affixed to each such door or hatch cover stating that it is not to be left open while the unit is afloat.
 - (iii) The closing appliances are to have strength, packing and means for securing which are sufficient to maintain watertightness under the design water pressure of the watertight boundary under consideration.
- (4) Internal openings fitted with appliances to ensure watertight integrity, which are to be kept permanently closed while afloat, are to comply with the following:

D7
(cont)

- (i) A signboard to the effect that the opening is always to be kept closed while afloat is to be fitted on the closing appliance in question.
- (ii) Opening and closing of such closure devices should be noted in the unit's logbook, or equivalent.
- (iii) Manholes fitted with bolted covers need not be dealt with as under (i).
- (iv) The closing appliances are to have strength, packing and means for securing which are sufficient to maintain watertightness under the design water pressure of the watertight boundary under consideration.

D7.4.3 General requirements related to weathertight integrity.

- (1) Any opening, such as an air pipe, ventilator, ventilation intake or outlet, non-watertight sidescuttle, small hatch, door, etc., having its lower edge submerged below a waterline associated with the zones indicate in (i) or (ii) below, is to be fitted with a weathertight closing appliance to ensure the weathertight integrity, when:
 - (i) a unit is inclined to the range between the first intercept of the right moment curve and the wind heeling moment curve and the angle necessary to comply with the requirements of D3.8.1 during the intact condition of the unit while afloat; and
 - (ii) a column stabilized unit is inclined to the range:
 - a) necessary to comply with the requirements of D3.8.3 (2)(b) and with a zone measured 4.0 m perpendicularly above the final damaged waterline per D3.8.3 (2)(a) referred to Fig.4, and
 - b) necessary to comply with the requirements of D3.8.3 (3)(b).
- (2) External openings fitted with appliances to ensure weathertight integrity, which are kept permanently closed while afloat, are to comply with the requirements of D7.4.2(4) (i) and (ii).

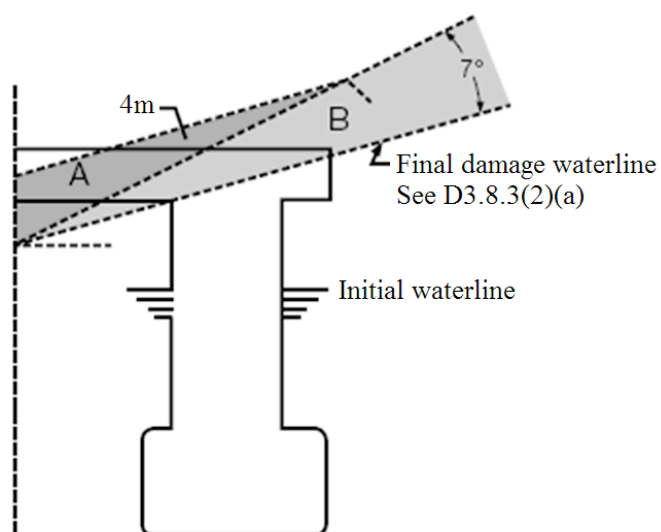
D7
(cont)

A - 4m zone of weathertightness
B - 7 degrees zone of weathertightness

Fig. 4**Minimum weathertight integrity requirements for column stabilized units**

- (3) External openings fitted with appliances to ensure weathertight integrity, which are secured while afloat are to comply with the requirements of D7.4.2(3) (i) and (ii).

End of
Document

D8

(1979)
 (Rev. 1
 1990)
 (Rev. 2
 1996)

Hazardous areas**D8.1 General**

D8.1.1 The unit should be classified into hazardous areas in accordance with D8.1.2 and D8.1.3 or alternatively with an acceptable code of practice.

D8.1.2 Hazardous areas are all those areas where, due to the possible presence of a flammable atmosphere arising from the drilling operations, the use without proper consideration of machinery or electrical equipment may lead to fire hazard or explosion.

D8.1.3 Hazardous areas are subdivided into Zones 0,1 or 2, the definitions of each category being as follows:

Zone 0 an area in which an explosive gas-air mixture is continuously present or present for long periods.

Zone 1 an area in which an explosive gas-air mixture is likely to occur in normal operating conditions.

Zone 2 an area in which an explosive gas-air mixture is not likely to occur, and if it occurs, it will only exist for a short time.

D8.1.4 The hazardous areas defined in D8.2.1 – D8.2.3 are those which normally apply to offshore drilling units for oil and gas exploration. Equipment for well testing is to be specially considered, if present.

The hazardous areas as specified may be extended or reduced depending on the actual arrangements in each case, by use of windshields, special ventilation arrangements, structural arrangements (e.g., low deck head), etc.

D8.1.5 For the purpose of D8:

- (i) An enclosed space is considered to be a space bounded by bulkheads and decks which may have doors, windows, or other similar openings.
- (ii) A semi-enclosed location is considered to be a location where natural conditions of ventilation are notably different from those on open decks due to the presence of structure such as roofs, windbreaks and bulkheads and which are so arranged that the dispersion of gas may not occur.

D8.2 Classification of areas

D8.2.1 Hazardous areas Zone 0 include:

- (i) The internal spaces of closed tanks and pipes of the mud-circulating system between the well and the final degassing discharge as well as oil and gas products, e.g. escape gas outlet pipes, or spaces in which an oil-gas-air mixture is continuously present or present for long periods.

D8.2.2 Hazardous areas Zone 1 include:

- (i) Enclosed spaces containing any part of the mud-circulating system that has an opening into the spaces and is between the well and the final degassing discharge.
- (ii) In outdoor or semi-enclosed locations except as provided for in (iv), the area within 1,5 m (5 ft) of the boundaries of any openings to equipment which is part of the mud system as specified in (i), any ventilation outlets of Zone 1 spaces, or any access to Zone 1 spaces.
- (iii) Pits, ducts or similar structures in locations which otherwise would be Zone 2 but which are arranged so that the dispersion of gas may not occur.



D8

cont'd

- (iv) Enclosed spaces or semi-enclosed locations that are below the drill floor and contain a possible source of release such as the top of a drilling nipple.
- (v) Enclosed spaces that are on the drill floor and which are not separated by a solid floor from the spaces in (iv).

D8.2.3 Hazardous areas Zone 2 include:

- (i) Enclosed spaces which contain open sections of the mud circulating system from the final degassing discharge to the mud pump suction connection at the mud pit.
- (ii) Outdoor locations within the boundaries of the drilling derrick up to a height of 3 m (10 ft) above the drill floor.
- (iii) Semi-enclosed derricks to the extent of their enclosures above the drill floor or to a height of 3 m (10 ft) above the drill floor, whichever is greater.
- (iv) Semi-enclosed locations below and contiguous with the drill floor and to the boundaries of the derrick or to the extent of any enclosure which is liable to trap gases.
- (v) Outdoor locations below the drill floor and within a radius of 3 m (10 ft) from a possible source or release such as the top of a drilling nipple.
- (vi) The areas 1,5 m (5 ft) beyond the Zone 1 areas specified in D8.2.2(ii) and beyond the semi-enclosed locations specified in D8.2.2(iv).
- (vii) Outdoor spaces within 1,5 m (5 ft) of the boundaries of any ventilation outlet from or access to a Zone 2 space unless D8.2.4(b) is applicable.
- (viii) Air locks between a Zone 1 and a non-hazardous area.

D8.2.4 Openings, access and ventilation conditions affecting the extent of hazardous zones

Except for operational reasons access doors or other openings should not be provided between:

- a non-hazardous space and a hazardous zone;
- a Zone 2 space and a Zone 1 space.

Where such access doors or other openings are provided, any enclosed space not referred to under D8.2.2 or D8.2.3 and having a direct access to any Zone 1 location or Zone 2 location becomes the same zone as the location except that:

- (a) an enclosed space with direct access to any Zone 1 location can be considered as Zone 2 if:
 - (i) the access is fitted with a gas-tight door opening into the Zone 2 space, and
 - (ii) ventilation is such that the air flow with the door open is from the Zone 2 space into the Zone 1 location, and
 - (iii) loss of ventilation is alarmed at a manned station;
- (b) an enclosed space with direct access to any Zone 2 location is not considered hazardous if:
 - (i) the access is fitted with a self-closing gas-tight door that opens into the non-hazardous location, and
 - (ii) ventilation is such that the air flow with the door open is from the non-hazardous space into the Zone 2 locations, and
 - (iii) loss of ventilation is alarmed at a manned station;
- (c) an enclosed space with direct access to any Zone 1 location is not considered hazardous if:
 - (i) the access is fitted with gas-tight self-closing doors forming an air lock, and
 - (ii) the space has ventilation overpressure in relation to the hazardous space, and
 - (iii) loss of ventilation overpressure is alarmed at a manned station.

Where ventilation arrangements of the intended safe space are considered sufficient by the Society to prevent any ingress of gas from the Zone 1 location, the two self-closing doors forming an air lock may be replaced by a single self-closing gas-tight door which opens into the non-hazardous location and has no hold-back device.



D8
cont'd**D8.3 Ventilation****D8.3.1 General**

Attention is to be given to ventilation inlet and outlet location and airflow in order to minimize the possibility of cross contamination. Inlets are to be located in non-hazardous areas as high and as far away from any hazardous area as practicable. Each air outlet is to be located in an outdoor area which, in the absence of the considered outlet, is of the same or lesser hazard than the ventilated space. Ventilation for hazardous areas is to be completely separate from that used for non-hazardous areas. Where passing through hazardous areas, the inlet ducts are also to have overpressure in relation to this area.

D8.3.2 Ventilation of hazardous areas

Enclosed hazardous spaces are to be provided with adequate ventilation with under pressure in relation to the less hazardous space or zone. The arrangement of ventilation inlet and outlet openings in the space is to be such that the entire space is efficiently ventilated, giving special consideration to location of equipment which may release gas, and to spaces where gas may accumulate.

The outlet air from Zone 1 and Zone 2 spaces is to be led in separate ducts to outdoor locations. The internal spaces of such ducts belong to the same Zone as the inlet space. Air inlet ducts designed for constant relative underpressures are to be rigidly constructed to avoid air leaks. Fans are to be designed so as to reduce the risk that sparks may occur.



D9

(1979)
 (Rev. 1
 1987)
 (Rev. 2
 1990)
 (Rev. 3
 1996)

Machinery**D9.1 General**

D9.1.1 The following Requirements apply to the machinery essential to the safe operation of the unit. They do not apply to equipment and systems used solely for the drilling operation, except in so far as safety is concerned.

Systems and equipment that are used solely for drilling and that may affect the safety of the unit on which they are installed may be designed to the alternative requirements of recognized standards acceptable to the Society.

D9.1.2 Self-propelled and non-self-propelled units

All propulsion and auxiliary machinery, steering arrangements, pressure vessels, pumps and piping systems necessary for the safe operation of the unit are to be constructed and installed in accordance with the relevant requirements of the Rules and as specified herein.

D9.1.3 Machinery Installations – Inclinations

D9.1.3.1 – All units All machinery, components and systems essential to the safe operation of a unit are to be designed to operate under the following static conditions of inclination:

1. when column stabilized units are upright and inclined to an angle up to 15° in any direction:
2. when self-elevating units are upright and inclined to an angle up to 10° in any direction:
3. when surface units are upright and level trim and when inclined to an angle of list up to 15° either way and simultaneously trimmed to an angle up to 5° by the bow or stern.

The Society may permit or require deviations from these angles, taking into consideration the type, size and service conditions of the unit.

D9.1.3.2 – Self Propelled Units – Main propulsion machinery and all auxiliary machinery essential to the propulsion and the safety of the unit should, as fitted in the unit, be capable of operating under the static conditions required by D9.1.3.1 and the following dynamic conditions:

1. column stabilized units 22.5° in any direction:
2. self-elevating units 15° in any direction:
3. surface units 22.5° rolling and simultaneously pitching 7.5° by bow or stern.

The Society may permit deviation from these angles, taking into consideration the type, size and service conditions of the unit.

D9.1.3.3 Emergency Source of Power On all units, the emergency generator and its prime mover and any emergency accumulator battery are to be capable of supplying the power required by D10.4.2 when upright and when inclined to the greater of the first intercept angles at which compliance with the intact and damage stability criteria of D3.8 are satisfied. However, in no case need the equipment be designed to operate when inclined more than:

1. 25° in any direction on a column stabilized unit:
2. 15° in any direction on a self-elevating unit: and
3. 22.5° about the longitudinal axis and/or when inclined 10° about the transverse axis on surface unit.



D9
cont'd**D9.2 Jacking systems**

D9.2.1 The jacking system is to be designed and constructed to maintain the safety of the unit in the event of failure of a critical component during operation of the jacking system. Suitable monitoring is to be provided at a manned control station to indicate such failure.

D9.3 Piping systems**D9.3.1 General**

Pipes are to be arranged inboard of the zone of assumed damage penetration unless special consideration has been taken in the damage stability review. (See D3 to D6).

D9.3.2 Piping systems carrying non-hazardous fluids are generally to be separate from piping systems which may contain hazardous fluids. Cross connection of the piping systems may be permitted where means for avoiding possible contamination of the non-hazardous fluid system by the hazardous medium are provided.

D9.3.3 Where air or steam is used to atomize well bore fluids prior to flaring, a non-return valve is to be fitted in the air or steam line. This valve should be part of the permanently installed piping, readily accessible and as close as possible to the burner boom. Alternative arrangements shown to provide an equivalent level of safety may be accepted by the Society.

D9.4 Valve arrangements**D9.4.1 General**

Where valves of piping systems are arranged for remote control and are power operated, a secondary means of operating the valves which may be manual control, is to be provided.

D9.4.2 Remote operation of sea-water inlet and discharge valves

Inlet and discharge valves in compartments situated below the assigned load line (normally unattended compartments) are to be provided with remote controlled valves. Where remote operation is provided by power actuated valves for sea-water inlets and discharges for operation of propulsion and power generating machinery, power supply failure of the control system is not to result in:

- (i) closing of open valves
- (ii) opening of closed valves.

Consideration will be given to accepting bilge alarms in lieu of remote operation for surface type and self-elevating units only.

D9.5 Ballast systems for column stabilized units**D9.5.1 General**

Each ballast tank is to be capable of being pumped out by at least two power-driven pumps, arranged so that tanks can be drained at all normal operating and transit conditions. The ballast pumps are to be of the self-priming type or be provided with a separate priming system.

D9.5.2 Capacity

The system is to be capable of raising the unit, starting from a level trim condition at deepest normal operating draft, to the severe storm draft, or a greater distance as may be specified by the Society, within three hours.



D9

cont'd

D9.5.3 System arrangement

The ballast system is to be arranged to prevent the inadvertent transfer of ballast water from one quadrant to any other quadrant of the unit. The system is also to be arranged so that the transfer of ballast water from one tank to any other tank through a single valve is not possible except where such a transfer could not adversely affect the stability of the unit.

D9.5.4 Operation in Damaged Condition

The ballast system is to be arranged so that even with any one pump inoperable, it is capable of restoring the unit to a level trim condition and draft acceptable to the Society with respect to stability, when subject to the damage conditions specified in D3.7.3.

D9.5.5 Control Features

Ballast pumps, ballast tank valves and sea chest valves are to be provided with a means of remote control from a central ballast control station. Pumps are also to be provided with a means of local control in the pump room. A manually operated independent means of control of the valves is also to be provided. This ballast control station and any back-up stations are to be readily accessible and protected from the weather when the unit is subject to the assumed conditions of severe storm and damage. Additionally, these stations are not to be located within the assumed damaged penetration zone. The central ballast control station is to include the following:

- (i) A valve position indicating system.
- (ii) A tank level indicating system.
- (iii) A draft indicating system.
- (iv) A means of communication between the central ballast control station and those spaces containing the alternative means of control for the ballast pumps and valves.

The control and indicating systems are to function independently of each other so that a failure in any one system will not affect the operation of the other systems. The ballast pump and ballast valve control systems are to be arranged so that the loss of any one of their components will not cause the loss of operation to the other pumps or valves.

To ensure that uncontrolled transfer of ballast water will not continue upon loss of power, ballast tank valves are to close automatically upon loss of power or be provided with an arrangement considered equivalent to the satisfaction of the Society.

D9.6 Bilge systems**D9.6.1 General**

In general, the bilge system is to be in accordance with the Rules. Compartments below deck containing essential equipment for operation and safety of the unit are to have a permanently installed bilge or drainage system. These compartments are to be drained with at least two bilge pumps, or equal.

All distribution boxes and manually operated valves in connection with the bilge pumping arrangements are to be in positions which are accessible under normal circumstances. Where such valves are located in normally unmanned spaces below the assigned load line and not provided with high bilge water level alarms, they are to be operable from outside the space.

D9.6.2 Size of bilge main

The cross-sectional area of the main bilge line is not to be less than the combined areas of the two largest branch suction.



D9.6.3 Size of bilge branch suction

The internal diameter of branch suction from each compartment is not to be less than stipulated by the following formula, to the nearest 5 mm (0.20 in):

$$d = 2,15\sqrt{A} + 25 \text{ mm} \qquad d = \sqrt{A/1500} + 1 \text{ in.}$$

where A is wetted surface in m² (ft²) of the compartment, excluding stiffening members when the compartment is half filled with water. The internal diameter of any bilge line is not to be less than 50 mm (2 in.).

D9.6.4 Size of Bilge Pumps

Each bilge pump is to be capable of giving a speed of water through the bilge main of not less than 2 m (6.6 ft.) per second. When more than two pumps are connected to the bilge system, their aggregate capacity is not to be less effective.

D9.6.5 Chainlockers

Chainlockers are to be capable of being drained by a permanently installed bilge or drainage system or by portable means. Means are to be provided for removal of mud and debris from the bilge or drainage system.

D9.6.6 Void Compartments

Void Compartments adjacent to the sea or to tanks containing liquids, and void compartments through which piping conveying liquids passes, are to be drained by permanently installed bilge or drainage systems or by portable means. If portable pumps are used, two are to be provided and both pumps and arrangements for pumping are to be readily accessible. Void compartments as defined above which are not provided with bilge or drainage systems in compliance with the above are to be accounted for in the units stability analysis.

D9.6.7 Bilge alarm

Propulsion rooms or pump rooms in lower hulls of column stabilized units which normally are unattended are to be provided with two independent systems of high level detection.

D9.6.8 Bilge suction from hazardous areas

Hazardous and non-hazardous areas are to be provided with separate drainage or pumping arrangements.

D9.6.9 The following additional requirements are applicable to column stabilized units:

1. Chain lockers which, if flooded, could substantially affect the unit's stability are to be provided with a remote means to detect flooding and a permanently installed means of dewatering. Remote indication of flooding is to be provided at the central ballast control station.
2. At least one of the pumps referred to in D9.6.1 and all pump-room bilge suction valves are to be capable of both remote and local operation.

D9.7 Tank vents and overflows

D9.7.1 Tank vents and overflows are to be located giving due regard to damage stability and the location of the final calculated immersion line in the assumed damage condition. (See D.7.4.2(c)) Tank vents and overflows which could cause progressive flooding are to be avoided unless special consideration has been taken in the damage stability review.



D9
cont'd

In cases where tank vents and overflows terminate externally or in spaces assumed flooded, the vented tanks are to be also considered flooded. In cases where tanks are considered damaged, the spaces in which their vents or overflows terminate are also to be considered flooded.

Vents and overflows from tanks not considered flooded as a result of damage and located above the final calculated immersion line may require to be fitted with automatic means of closing.

D9.7.2 Vent size

The size of the vents is to be in accordance with the Rules with due consideration being given to the design pressure of the tank.

D9.8 Sounding arrangements**D9.8 .1 General**

All tanks are to be provided with separate sounding pipes, or approved remote level indicating system. Where a sounding pipe exceeds 20 m (65.6 ft) in length, the minimum internal diameter 38 mm (1.5 in.) as required by the Rules is to be increased to at least 50 mm (2 in.).

D9.8.2 Additional Sounding

Where a remote level indicating system is used, an additional sounding system is to be provided for tanks which are not always accessible.

D9.8.3 Void Compartments

Void compartments adjacent to the sea or tanks containing liquids, and void compartments through which piping carrying liquids passes are to be fitted with separate sounding pipes, approved tank liquid level indicating apparatus or be fitted with means to determine if the void tanks contain liquids. Voids as defined above which do not comply with this requirement are to be accounted for in the unit's stability analysis.



D9

cont'd

D9.9 Low flash point fuels

D9.9.1 General

Where it is intended to burn fuels of a flash point below 60°C (140°F) but not less than 43°C (110°F), closed cup test, this fact is to be indicated clearly on the arrangement submitted. Vent heads of an approved type with flame arrestors are to be fitted to vent pipes. Consideration may be given to other arrangements. The use of fuels of a flash point lower than 43°C (110°F) closed cup test will require special consideration of storage and handling facilities and controls as well as the electrical installation and ventilation provisions.

D9.9.2 Fuel storage for helicopter facilities

Areas where such fuel tanks are situated and fuelling operations conducted are to be suitable isolated from enclosed spaces or other areas which contain a source of vapour ignition. Vent heads of an approved type with flame arrestors are to be fitted to vent pipes. Fuel storage tanks are to be of approved metallic construction and are to be adequate for the installation. Special attention is to be given to the design, mounting and securing arrangements and electrical bonding of the tank and fuel transfer system. The storage and handling area is to be permanently marked. Coamings or other arrangements are to be provided to contain fuel-oil spills.

D9.10 Machinery installations in hazardous areas

D9.10.1 Combustion engines in hazardous areas

Generally, combustion engines are not to be installed in hazardous areas. When this cannot be avoided, special consideration may be given to the arrangement.

D9.10.2 Boilers in hazardous areas

Fired boilers are not to be installed in hazardous areas.

D9.11 Installation of internal combustion engines and boilers

D9.11.1 Exhaust outlets

Exhaust outlets of internal combustion engines are to be fitted with efficient spark arresting devices and shall discharge outside the hazardous areas. Exhaust outlets of fired boilers are to discharge outside hazardous areas.

D9.11.2 Exhaust pipes

Exhaust piping is to be installed in accordance with the Rules. Exhaust pipe insulation is to be protected against possible oil absorption.

D9.11.3 Air intakes

Air intakes for internal combustion engines shall be not less than 3 m (10 ft) from the hazardous areas as delineated in D8.2.

D9.12 High pressure piping for drilling operations

D9.12.1 General

Permanently installed piping systems for drilling operations are to comply with an acceptable standard or code.



D9
cont'd**D9.13 Initial start arrangement**

D9.13.1 General

Provision is to be made for initial starting on board with the unit in a "dead ship" mode without the use of external aid.

D9.14 Control and monitoring

D9.14.1 General

Where propulsion machinery spaces are normally unattended during transit, the control and monitoring systems are to be constructed and installed in accordance with the applicable requirements of the Rules.



D10

(1979)
 (Rev 1
 1987)
 (Rev 2
 1990)

Electrical installations**D10.1 General**

D10.1.1 The following Requirements apply to electrical equipment essential to the safe operation of the unit. They do not apply to electrical equipment and systems used solely for the drilling operation except in so far as safety is concerned. Attention should, however, be given to any relevant statutory regulation of the National Authority of the country in which the unit is to be registered.

D10.2 Design and construction

D10.2.1 Every unit is to be provided with a main source of electrical power which is to include at least two generators. Electrical propelling machinery and associated equipment together with auxiliary services essential for the safety of the unit are to be constructed and installed in accordance with the relevant requirements of the Rules and as specified herein. The following equipment is regarded as essential:

- (i) Ventilation of hazardous areas and those areas maintained at an overpressure to exclude the ingress of dangerous gases.
- (ii) Navigation and special purpose lights.
- (iii) Lights for all machinery spaces, control stations, alleyways, stairway and exits.
- (iv) Fire pumps.
- (v) Propulsion equipment.
- (vi) Bilge pumps.
- (vii) Ballast pumps for column stabilized units.

D10.2.2 The design and installation of other equipment including that used for drilling operations is to be such that there is minimal risk of fire due to its failure. It must, as a minimum, comply with an acceptable specification, standard or code, revised where necessary, for ambient conditions.

D10.2.3 Essential lighting should be supplied from at least two final sub-circuits in such a way that failure of any one of the circuits does not leave the space in darkness. For lighting in hazardous areas or spaces, switches are to be of the two-pole type and wherever practicable located in a non-hazardous area.

D10.3 Cables and types of electrical equipment permitted in hazardous areas

D10.3.1 Electrical equipment in hazardous areas

- (a) Zone 0 Areas:
Certified intrinsically safe circuits or equipment and associated wiring.
- (b) Zone 1 Areas:
Certified intrinsically safe circuits or equipment and associated wiring.
Certified flameproof (explosion proof) equipment.
Certified increased safety equipment; for increased safety motors due consideration should be given to the protection against overcurrent.
Pressurized enclosure type equipment which is acceptable to the Society.
Through runs of cables.
- (c) Zone 2 Areas:
All equipment approved for Zone 1 Areas.
Any equipment of a type which ensures absence of sparks or arcs and of "hot spots" during normal operation and which is acceptable to the Society.



D10

cont'd

D10.3.2 Cables in hazardous areas

- (a) Zone 0 Areas:
Cables associated with intrinsically safe circuits.
- (b) Zone 1 Areas – all cables shall be sheathed as follows:
Nonmetallic impervious sheath plus metal screening or braiding for earth detection.
Copper sheath plus nonmetallic outer sheath for earth detection (for mineral insulated cable only).
- (c) Zone 2 Areas – all cables are to be sheathed as follows:
As for Zone 1 areas.
Nonmetallic sheath without metal screening or braiding, provided the cable is adequately protected against mechanical damage.

D10.4 Emergency source of power

D10.4.1 A self-contained emergency source of power is to be installed in a non-hazardous space and should be located on or above the uppermost continuous deck and above the worst damage waterline and inboard of the damage conditions specified in D3.7.3. Its location and arrangement in relation to the main source of electric power is to be such as to ensure that a fire, flooding or other failure in the space containing the main source will not interfere with the supply or distribution of emergency power.

D10.4.2 The power available is to be sufficient to supply for at least 18 hours all services necessary for the safety of all on board in an emergency, particular attention being given to:

- (i) Navigation and special purpose lights and warning system.
- (ii) Emergency lighting for machinery spaces, control stations, alleyways, stairways and exits.
- (iii) General alarm and communications systems.
- (iv) Fire and gas detection systems and their alarms.
- (v) Fire extinguishing systems.
- (vi) Permanently installed diving equipment necessary for the safe conduct of diving operations, if dependent upon the unit's electrical power.
- (vii) Abandonment systems dependent on electric power including lighting for embarkation stations.
- (viii) Emergency lighting for personnel lift cars and personnel lift trunks.
- (ix) Emergency lighting in all spaces from which control of the drilling process is performed and where controls of machinery essential for this process, or devices for emergency switching-off of the power plant are located.
- (x) Emergency lighting at the storage position(s) for firemen's outfits.
- (xi) Emergency lighting at the sprinkler pump if any, at one of the fire pumps if dependent upon the emergency generator for its source of power, at the emergency bilge pump if any, and at their starting positions.
- (xii) Emergency lighting on helicopter decks.
- (xiii) The capability of closing the blow-out preventer and of disconnecting the unit from the well head arrangement, if electrically controlled, unless it has an independent supply from an accumulator battery suitably located for use in an emergency and sufficient for the period of 18 hours.
- (xiv) On Column Stabilized Units: Ballast valve control system, ballast valve position indicating system, draft level indicating system, tank level indicating system, and the largest single ballast pump required by D9.5.1.

D10.4.3 Where the emergency source of power is a generator not fitted with an automatic starting device and an automatic connection to the emergency switchboard, a transitional source of emergency power is to be installed.

This is to be storage batteries of sufficient capacity to supply for at least 30 minutes:

- Emergency lighting
- Fire detection system
- General alarm and communications systems



D10

cont'd

Blow-out preventer.

D10.4.4 Arrangements are to be such that the transitional source of emergency power will come into operation automatically in the event of failure of the main electrical supply.

D10.5 Emergency shutdown facilities**D10.5.1 Emergency conditions due to drilling operations**

In view of exceptional conditions in which the explosion hazard may extend outside the areas defined in D8, special arrangements should be provided to facilitate the selective disconnection of shutdown of :

Ventilating system

All electrical equipment outside Zone 1 areas, except where of a certified safe type for Zone 1 applications.

Main electrical generators and prime movers.

Emergency equipment except those items listed in D10.5.2.

Emergency generators.

Initiation of the foregoing shutdown of facilities will be the operator's responsibility. The initiated action may vary according to the nature of the emergency. A recommended sequence of shutdowns should be included in the Operating Booklet (see D1.3.4).

D10.5.2 Equipment to remain operational after emergency shutdown.

At least the following facilities are to be operable after an emergency shutdown. Equipment which is located in spaces other than enclosed spaces and arranged to be operated after complete shutdown as given D10.5.1 is to be suitable for installation in Zone 2 locations. Such equipment, when located in enclosed spaces, is to be suitable for its intended application to the satisfaction of the society:

Emergency lighting required by D10.4.2 for half an hour;

Blow-out preventer control system;

General alarm system;

Public address system; and

Battery supplied radio communication installations.

D10.6 Earthing (grounding) arrangements

D10.6.1 Where not obtained through normal construction, arrangements are to be provided to effectively earth (ground) all machinery, metal structures of derricks, masts and helicopter platforms.

D10.6.2 Cathodic protection

Details of impressed-current cathodic protection systems, including installation and locations, are to be submitted when such systems are installed. ◀◀

D11 Safety features

(1979)
(Rev.1
1990)
(Rev.2
1996)
(Rev.3
Jan
2012)

D11.1 Fire protection and extinction

D11.1.1 General

Fire protection arrangements and fire extinguishing systems are to be in accordance with the Rules as specified herein. Fire control plans are to be submitted for review on which the following, as a minimum, should be clearly shown:

- (1) Locations of fire control stations;
- (2) Various fire sections enclosed by various classes of fire divisions;
- (3) Arrangement of fire detectors and manual fire alarm stations;
- (4) Arrangement of combustible gas detectors;
- (5) Arrangement of hydrogen sulphide gas detectors;
- (6) Locations of respiratory protection equipment for hydrogen sulphide;
- (7) General alarm actuating positions;
- (8) Arrangement of various fire-extinguishing appliances;
- (9) Locations of Fighter's Outfits;
- (10) Location of Helicopter Crash Kit;
- (11) Arrangement of water spray nozzles and sprinklers (if fitted);
- (12) Locations of emergency shutdown (such as oil fuel source shutdown, engine shutdown, etc.) stations;
- (13) The Ventilating system including Fire dampers positions, Ventilating Fans control positions with indication of identification numbers of Ventilating Fans serving each section;
- (14) Arrangement of fire/watertight doors and their remote control positions;
- (15) Blowout preventer control positions;
- (16) Escape route and means of access to different compartments, decks, etc.;

Notes:

1. This UR apply to mobile offshore drilling units contracted for construction on and after 1 January 2013.
2. The "contracted for construction" date means the date on which the contract to build the vessel is signed between the prospective owner and the shipbuilder. For further details regarding the date of "contract for construction", refer to IACS Procedural Requirement (PR) No. 29.

D11
(cont)

- (17) Locations of Emergency Escape Breathing Devices (EEBD); and
- (18) Arrangement of emergency muster stations and life-saving appliances.

D11.1.2 Governmental authority

Attention is directed to the appropriate governmental authority in each case, as there may be additional requirements, depending on the size, type and intended service of the units as well as other particulars and details. Consideration will be given to fire protection arrangements and fire extinguishing systems which comply with the published requirements of the governmental authority of the country in which the unit is to be registered.

Also, attention is directed to Chapter 9 of the IMO Code for the Construction and Equipment of Mobile Offshore Drilling Units, 2009, which contains minimum requirements for structural fire protection.

D11.2 Fire fighting water supply

D11.2.1 Fire pumps

There are to be at least two independently driven fire pumps. The pumps, their source of power and piping and valves are to be so arranged that a fire in any one compartment will not put all fire pumps out of action.

D11.2.2 Pressure

Each fire pump is to be able to maintain a pressure of at least 350 kPa (50 lb/in²) at any hydrants with two 19 mm (3/4 in.) nozzles in action. In addition where a foam system is provided for protection of the helicopter deck, the pump should be capable of maintaining a pressure of 700 kPa (100 lb/in²) at the foam installation and the water consumption used for foam system is to be added to the pump capacity. If the water consumption for any other fire protection or fire-fighting purpose should exceed the rate of the helicopter deck foam installation, this consumption should be the determining factor in calculating the required capacity of the fire pumps.

D11.2.3 Nozzles

Dual purpose jet spray nozzles are to be fitted throughout the unit with a minimum nozzle diameter of 12 mm (1/2 in.) for accommodation and service spaces and with a maximum diameter of 19 mm (3/4 in.) for machinery spaces and exterior locations.

D11.2.4 Supply

- (1) At least two water supply sources (sea chests, valves, strainers and pipes) are to be provided and so arranged that one supply source failure will not put all supply sources out of action.
- (2) For the self-elevating units, the following additional fire water supply measures are to be provided:
 - (a) Water is to be supplied from sea water main filled by at least two submersible pumping systems. One system failure will not put the other system(s) out of function, and
 - (b) Water is to be supplied from drill water system while unit lifting or lowering. Water stored in the drill water tank(s) is not less than 40 m³ plus engine cooling water consumptions before

D11
(cont)

unit lifting or lowering. Alternatively, water may be supplied from buffer tank(s) in which sea water stored is not less the quantity as the above mentioned.

D11.3 Fire extinguishing systems

D11.3.1 Fixed and portable fire extinguishing systems are to be provided in accordance with the Rules except the requirements of D11.3.2 and D11.3.3.

D11.3.2 Fixed fire extinguishing systems on drilling and areas

- (a) A fixed water spray system is to be provided to protect drilling area. The minimum water application rate is not less than $20.4 \text{ l/min}\cdot\text{m}^2$, or
- (b) At least two dual-purpose (jet/spray) fire monitors are to be installed to cover drilling and well test areas. The minimum capacity of each monitor is not less than $100\text{m}^3/\text{h}$. The monitors may be operated either remotely or locally. Monitor arranged for local operation should be sited on an accessible protected position.

D11.3.3 Fixed fire extinguishing systems on mud processing area

A suitable fixed foam system is to be provided. The system is to be capable of delivering foam solution at a rate of not less than $6.5 \text{ l/min}\cdot\text{m}^2$ ($4.1 \text{ l/min}\cdot\text{m}^2$ for Aqueous Film Forming Foam or Film-Forming Fluoroprotein Foam) for 15 minutes. Alternatively, a gas fixed fire extinguishing system may be used for enclosed mud processing spaces.

D11.4 Fire fighting equipment for helicopter facilities

D11.4.1 General

Where areas of a unit are designated for helicopter facilities, the fire fighting equipment as given in D11.4.2 and D11.4.3 are to be provided and so arranged as to adequately protect both the helicopter deck and fuel storage areas.

D11.4.2 Portable fire extinguishers

- (a) Primary extinguishers: dry powder extinguishers of a total capacity of not less than 45 kg (100 lb).
- (b) Back-up extinguishers: CO_2 extinguishers of a total capacity of not less than 18 kg or equivalent, one of these extinguishers being so equipped as to enable it to reach the engine area of any helicopter using the deck. The back-up extinguishers are to be located so that they would not be vulnerable to the same damage as the primary extinguishers.

D11.4.3 Fixed fire fighting systems

- (a) Fire water system: at least two approved nozzles of jet/spray type and hoses sufficient in length to reach any part of the helicopter deck.
- (b) Fixed foam system: A suitable foam application system consisting of monitors or hose streams or both is to be installed. The system is to be capable of delivering foam solution at a rate of not less than $6 \text{ l/min}\cdot\text{m}^2$ ($4.1 \text{ l/min}\cdot\text{m}^2$ for Aqueous Film Forming Foam or Film-Forming Fluoroprotein Foam) for at least 5 minutes.

D11
(cont)**D11.5 Alarms and public address**

D11.5.1 General alarms

- (1) A general alarm system is to be provided and so installed as to be clearly perceptible in all parts of the unit. Alarm signal devices are to be provided which will produce a distinctive and strong note.

The signals used should be limited to: general emergency, toxic gas (hydrogen sulphide), combustible gas, fire alarm and abandon unit signals.

The signals given over the general alarm system should be supplemented by instructions over the public address system.

- (2) At least in the following spaces general alarm is to be capable of being operated:

- (a) Main control station;
- (b) Drilling console;
- (c) Navigating bridge (if any); and
- (d) Fire control station (if any).

D11.5.2 Mud system level alarms

A suitable audible and visual alarm to indicate significant increase or decrease in the level of the contents of the mud pit is to be provided at the control station for drilling operations and at the mud pit. Equivalent means to indicate possible abnormal conditions in the drilling system may be considered by the Society.

D11.5.3 Ventilation system alarm

See D8.2.4.

D11.5.4 Public address

D11.5.4.1 The public address system is to be a loudspeaker installation enabling the broadcast of messages into all spaces where personnel are normally present and muster stations. It is to allow for the broadcast of messages from navigation bridge, central control room, emergency response centre, engine control room, ballast control station, jacking control station and drilling console. It is to be installed with regard to acoustically marginal conditions and not require any action from the addressee. It is to be protected against unauthorized use.

D11.5.4.2 The minimum sound pressure levels for broadcasting emergency announcements are to be:

- (1) In interior spaces 75dB(A) and at least 20dB(A) above the speech interference level; and
- (2) In exterior spaces 80dB(A) and at least 15dB(A) above the speech interference level.

D11
(cont)**D11.6 Fire detection and alarm systems**

D11.6.1 General

D11.6.1.1 Spaces having a fire risk, in principle, should be provided with an automatic fire detection and alarm system.

D11.6.1.2 In selecting the type of detectors, their following features should be taken into account:

- (a) Capability to detect fire at the incipient stage;
- (b) Ability to avoid spurious alarm and trips; and
- (c) Suitability to the located environment.

D11.6.1.3 The fire detection main indicator board is to be at a manned control station and is to be clearly to indicate where fire has been detected.

D11.6.2 Machinery spaces

Fire detectors are to be fitted in normally unattended machinery spaces. Detection systems using only thermal detectors, in general, are not to be permitted.

D11.6.3 Accommodation and service spaces

An automatic fire detection and alarm system is to be provided in all accommodation and service spaces.

Accommodation space is to be fitted with smoke detectors.

Thermal detectors are to be fitted in galleys.

D11.6.4 Electrical rooms and control stations

Smoke detectors are to be provided in all electrical rooms and control stations.

D11.6.5 Drilling and mud processing areas

Flame or thermal detectors are to be installed in open drilling and/or mud processing areas. Smoke detectors may be used in enclosed mud processing areas.

D11.6.6 Manually operated alarm system

Sufficient manual fire alarm stations are to be installed throughout the accommodation spaces, service spaces and control stations. One manually operated call point is to be located at each exit. Manually operated call points are to be readily accessible in the corridors of each deck such that no part of the corridor is more than 20 m from a manually operated call point.

Measures are to be taken to prevent inadvertent operation of the manual call alarm system.

D11
(cont)**D11.7 Combustible gas detection and alarm systems**

D11.7.1 Areas for protection

Fixed automatic combustible gas detection and alarm systems are to be provided for the following areas:

- a) Cellar deck
- b) Drill floor
- c) Mud pit area
- d) Shale shaker area
- e) Enclosed spaces containing the open components of mud circulation system from the bell nipple to the mud pits.
- f) Ventilation intakes of enclosed machinery spaces contiguous to hazardous areas and containing internal combustion engines and boilers; and
- g) Ventilation intakes and near other openings of accommodation spaces.

D11.7.2 Alarms

The gas detectors are to be connected to an audible and visual alarm system with indicators on the drill floor and in the main control station. The alarm system is to clearly indicate the location and concentration of the gas hazard. The combustible gas detectors are to alarm at not more than 25% and at 60% of the lower explosive limit (LEL).

D11.7.3 Portable combustible gas detectors

In addition to the fixed automatic gas detection system, two portable combustible gas detectors are to be provided on the unit.

D11.8 Hydrogen sulphide detection and alarm system

D11.8.1 Areas for protection

A fixed automatic hydrogen sulphide gas detection and alarm system are to be provided for the following areas:

- (a) Drill area;
- (b) Mud processing area; and
- (c) Well test area.

D11.8.2 Alarms

The detectors are to be connected to an audible and visual alarm system with indicators in main control room. The system is clearly to indicate where gas has been detected.

Low level alarm set at 10 ppm and high level alarm set not higher than 300 ppm are to be designed. The high level alarm is to activate an evacuation alarm.

If the alarm at the main control point is unanswered within 2 min, the toxic gas (hydrogen sulphide) alarm and the helideck status light is to be automatically activated.

D11.8.3 Portable hydrogen sulphide gas detectors

At least two portable hydrogen sulphide gas monitoring devices should be provided on the unit.

D11
(cont)**D11.9 Respiratory protection equipment for hydrogen sulphide**

D11.9.1 A self-contained breathing apparatus (SCBA) positive-pressure/pressure-demand breathing equipment with full-face piece and rated for a minimum of 30 minutes is to be provided for each person in working areas where hydrogen sulphide may be encountered, and each person in other areas is to be provided with a SCBA rated for a minimum of 15 minutes, or

D11.9.2 A positive-pressure/pressure-demand air line breathing equipment coupled with a SCBA equipped low pressure warning alarm and rated for a minimum of 15 minutes is to be provided for each person on board the unit.

Breathing air supply line stations are to be provided at least in the following areas:

- (a) Living quarter;
- (b) Muster/evacuation area;
- (c) Drilling areas;
- (d) Mud processing areas; and
- (e) Other working areas.

End of Document

D12
(1989)

UR D12 was re-categorized as UR Z15 in August 2002.

