

M74 Installation of Ballast Water Management Systems

(Sept
2015)
(Rev.1
May
2016)

1. Application

In addition to the requirements contained in BWM Convention (2004), the following requirements are applied to the installation of Ballast Water Management Systems.

2. Definitions

2.1 Ballast Water Management System (hereinafter referred to as 'BWMS') means any system which processes ballast water such that it meets or exceeds the Ballast Water Performance Standard in Regulation D-2 of the BWM Convention. The BWMS includes ballast water management equipment, all associated control equipment, monitoring equipment and sampling facilities.

2.2 Dangerous gas means any gas which may develop an explosive and/or toxic atmosphere being hazardous to the crew and/or the ship, e.g. hydrogen (H₂), hydrocarbon gas, ozone (O₃), chlorine (Cl₂) and chlorine dioxide (ClO₂), etc.

2.3 Hazardous area means an area in which an explosive gas atmosphere is or may be expected to be present, in quantities such as to require special precautions for the construction, installation and use of equipment. When a gas atmosphere is present, the following hazards may also be present: toxicity, asphyxiation, corrosivity and reactivity.

2.4 Dangerous liquid means any liquid that is identified as hazardous in the Material Safety Data Sheet or other documentation relating to this liquid.

Note:

1. This UR is to be uniformly implemented by IACS Societies for BWMS:
 - i) where an application for approval for the plans of BWMS is made on or after 1 January 2017; or
 - ii) which is installed in ships contracted for construction on or after 1 January 2017.
2. Rev.1 of this UR is to be uniformly implemented by IACS Societies for BWMS:
 - i) where an application for approval for the plans of BWMS is made on or after 1 January 2017; or
 - ii) which is installed in ships contracted for construction on or after 1 January 2017.
3. The "contracted for construction" date means the date on which the contract to build the vessel is signed between the prospective owner and the shipbuilder. For further details regarding the date of "contract for construction", refer to IACS Procedural Requirement (PR) No. 29.

M74

(cont)

3. Installation**3.1 General requirements**

3.1.1 All valves, piping fittings and flanges are to comply with the relevant requirements of UR P2 and P4. In addition, special consideration can be given to the material used for this service with the agreement of Society.

3.1.2 The BWMS is to be provided with by-pass or override arrangement to effectively isolate it from any essential ship system to which it is connected.

3.1.3 The BWMS is to be operated at a flow rate within the Treatment Rated Capacity (TRC) range specified in the Type Approval Certificate (TAC) issued by the Flag Administration.

3.1.4 Where a vacuum may occur in the ballast line due to the height difference, a suitable protection means is to be provided, e.g. P/V valves or breather valves, and their outlets are to be led to safe area on open deck.

3.1.5 Electric and electronic components are not to be installed in a hazardous area unless they are of certified safe type for use in the area. Cable penetrations of decks and bulkheads are to be sealed when a pressure difference between the areas is to be maintained.

3.1.6 Where the operating principle of the BWMS involves the generation of a dangerous gas, the following requirements are to be satisfied:

.1 Gas detection equipment is to be fitted in the spaces where dangerous gas could be present, and an audible and visual alarm is to be activated both locally and at the BWMS control station in the event of leakage. The gas detection device is to be designed and tested in accordance with IEC 60079-29-1 or recognized standards acceptable to the Society.

.2 The ventilation line of a space where dangerous gas could be present is to be led to a safe area on open deck.

.3 The arrangements used for gas relieving, i.e. degas equipment or equivalent, are to be provided with monitoring measures with independent shutdown. The open end of the gas relieving device is to be led to a safe area on open deck.

3.1.7 Ballast piping, including sampling lines from ballast tanks considered as hazardous areas, is not to be led to an enclosed space regarded as a safe area, without any appropriate measures, except ships carrying liquefied gases in bulk. However, a sampling point for checking the performance of BWMS, for ballast water containing dangerous gas, may be located in a safe area provided the following requirements are fulfilled:

.1 The sampling facility (for BWMS monitoring/control) is to be located within a gas tight enclosure (hereinafter, referred to as a 'cabinet'), and the following (i) through (iii) are to be complied.

i) In the cabinet, a stop valve is to be installed in each sample pipe.

ii) Gas detection equipment is to be installed in the cabinet and the valves specified in i) above are to be automatically closed upon activation of the gas detection equipment.

M74

(cont)

iii) Audible and visual alarm signals are to be activated both locally and at the BWMS control station when the concentration of explosive gases reaches a pre-set value, which should not be higher than 30% of the lower flammable limit (LFL) of the concerned product.

.2 The standard internal diameter of sampling pipes is to be the minimum necessary in order to achieve the functional requirements of the sampling system.

.3 The measuring system is to be installed as close to the bulkhead as possible, and the length of measuring pipe in any safe area is to be as short as possible.

.4 Stop valves are to be located in the safe area, in both the suction and return pipes close to the bulkhead penetrations. A warning plate stating "Keep valve closed when not performing measurements" is to be posted near the valves. Furthermore, in order to prevent backflow, a water seal or equivalent arrangement is to be installed on the hazardous area side of the return pipe.

.5 A safety valve is to be installed on the hazardous area side of each sampling pipe.

3.1.8 For the spaces, including hazardous areas, where toxicity, asphyxiation, corrosivity or reactivity is present, these hazards are to be taken into account and additional precautions for the ventilation of the spaces and protection of the crew are to be considered.

3.2 Additional requirements for tankers:

3.2.1 Hazardous area classification is to be in accordance with IEC 60092-502.

3.2.2 For tankers carrying flammable liquids having a flashpoint not exceeding 60 °C or products listed in the IBC Code having a flashpoint not exceeding 60 °C or cargoes heated to temperature above their flashpoint and cargoes heated to temperature within 15 °C of their flashpoint. In general, two independent BWMS may be required – i.e. one for ballast tanks in hazardous areas and the other for ballast tanks in non-hazardous areas.

3.2.3 The interconnection of ballast piping between hazardous areas and in non-hazardous areas may be accepted if an appropriate isolation arrangement is applied. Means of appropriate isolation are as follows:

.1 Two screw down check valves in series with a spool piece, or

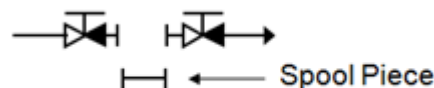

.2 Two screw down check valves in series with a liquid seal at least 1.5 m in depth, or

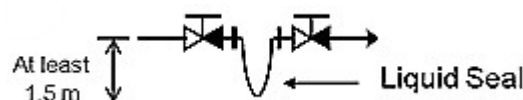

M74

(cont)

.3 Automatic double block and bleed valves and a non-return valve

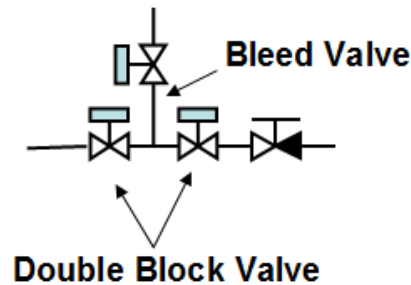

Examples of appropriate isolation arrangements are shown in Annex I. Isolation arrangements are to be fitted on the exposed deck in the hazardous area. Also, ballast water originating from a hazardous area is not to discharge into a non-hazardous area, except as given by 3.1.7.

3.3 Ventilation

3.3.1 BWMS not in hazardous areas:

.1 A BWMS that does not generate dangerous gas is to be located in an adequately ventilated area.

.2 A BWMS that generates dangerous gas is to be located in a space fitted with a mechanical ventilation system providing at least 6 air changes per hour or as specified by the BWMS manufacturer, whichever is greater.

3.3.2 BWMS in hazardous areas:

A BWMS, regardless of whether or not it generates dangerous gas, is to be located in a space fitted with mechanical ventilation complying with relevant requirements, e.g. IEC60092-502, IBC Code, IGC Code, etc.

3.4 Special requirements:

3.4.1 The length of pipe and the number of connections are to be minimised in piping systems containing dangerous gases/liquids in high concentration. The following requirements are also to be satisfied:

.1 Pipe joints are to be of welded type except for connections to shut off valves, double walled pipes or pipes in ducts equipped with mechanical exhaust ventilation. Alternatively it is to be demonstrated that risk of leakage is minimized and the formation of toxic or flammable atmosphere is prevented.

.2 Location of the piping system is to be away from heat sources and protected from mechanical damage.

3.4.2 For BWMS using chemical substances, handling procedures are to be in accordance with the Material Safety Data Sheet and BWM.2/Circ.20, and the following measures are to be taken as appropriate:

.1 The materials used for the chemical storage tanks, piping and fittings are to be resistant to such chemicals.

M74
(cont)

- .2 Chemical storage tanks are to have sufficient strength and be constructed such that maintenance and inspection can be easily performed.
- .3 Chemical storage tank air pipes are to be led to a safe area on open deck.
- .4 An operation manual containing chemical injection procedures, alarm systems, measures in case of emergency, etc, is to be kept onboard.
- 3.4.3 Where the BWMS is installed in an independent compartment, the compartment is to be:
 - .1 Provided with fire integrity equivalent to other machinery spaces.
 - .2 Positioned outside of any combustible, corrosive, toxic, or hazardous areas unless otherwise specifically approved.
- 3.4.4 A risk assessment may be conducted to ensure that risks, including but not limited to those arising from the use of dangerous gas affecting persons on board, the environment, the structural strength or the integrity of the ship are addressed.

4. Automation

- 4.1 In case of any by-pass or override operation of BWMS, an audible and visual alarm is to be given and these events are to be automatically recorded in control equipment. The valves in the by-pass line which trigger the by-pass operation are to be remote-controllable by control equipment or fitted with open/close indicator for automatic detection of the by-pass event.

M74 Annex I

(cont)

- BWMS which does not require after-treatment

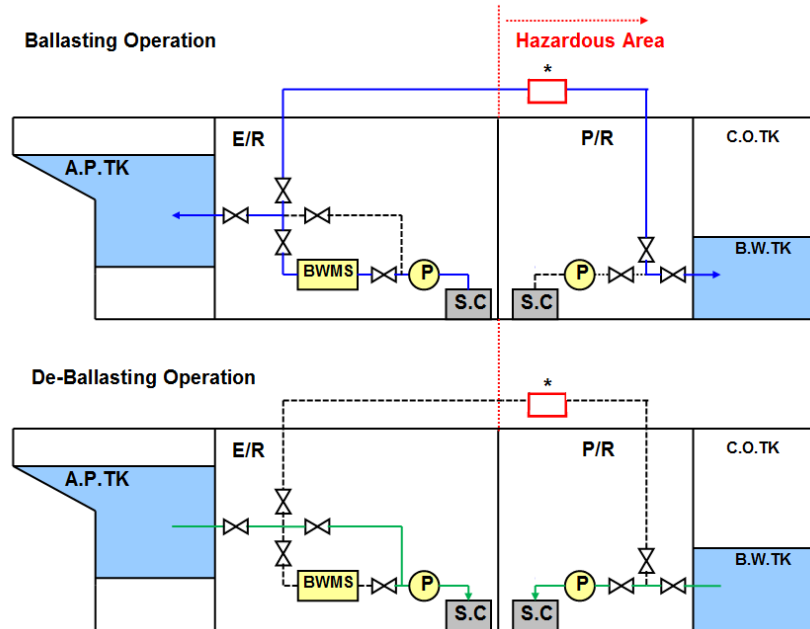

- BWMS which requires after-treatment (Injection type)

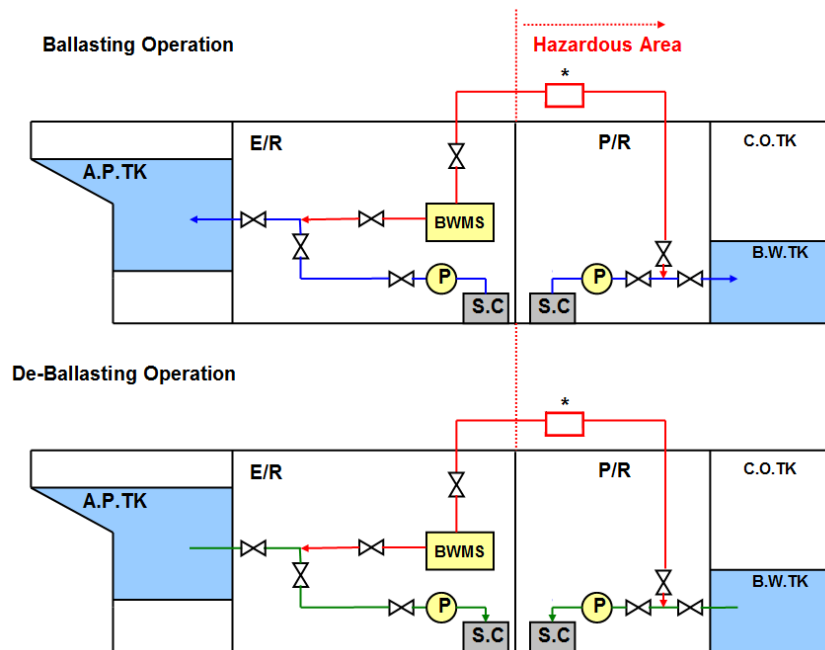

* : Appropriate Isolation Means: Two (2) screw down check valves in series with a spool piece or a liquid seal, or automatic double block and bleed valves

M74
(cont)

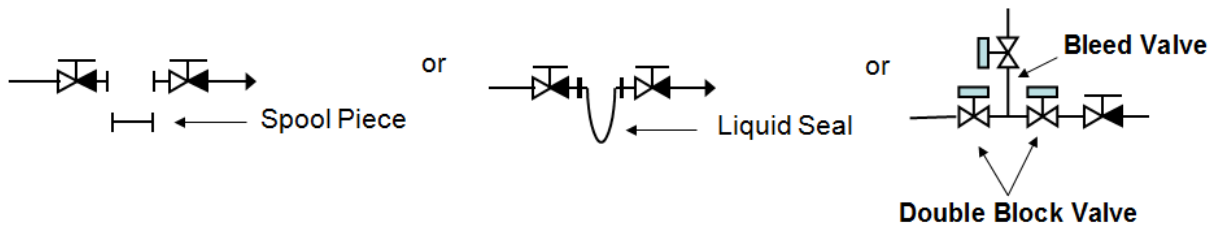

End of Document