

W22 Offshore Mooring Chain

(1993)
 (Rev.1
 1997)
 (Rev.2
 July
 1999)
 (Rev.3
 May
 2004)
 (Rev.4
 Sept
 2006)
 (Rev.5
 Dec
 2009)
 (Corr.1
 June
 2011)
 (Rev.6
 June
 2016)

1 GENERAL REQUIREMENTS

1.1 Scope

1.1.1 These requirements apply to the materials, design, manufacture and testing of offshore mooring chain and accessories intended to be used for applications such as: mooring of mobile offshore units, mooring of floating production units, mooring of offshore loading systems and mooring of gravity based structures during fabrication.

1.1.2 Mooring equipment covered are common stud and studless links, connecting common links (splice links), enlarged links, end links, detachable connecting links (shackles), end shackles, subsea connectors, swivels and swivel shackles.

1.1.3 Studless link chain is normally deployed only once, being intended for long-term permanent mooring systems with pre-determined design life.

1.1.4 Requirements for chafing chain for single point mooring arrangements are given in Appendix A.

1.2 Chain grades

1.2.1 Depending on the nominal tensile strength of the steels used for manufacture, chains are to be subdivided into five grades, i.e.: R3, R3S, R4, R4S and R5.

1.2.2 Manufacturers propriety specifications for R4S and R5 may vary subject to design conditions and the acceptance of the Classification Society.

1.2.3 Each Grade is to be individually approved. Approval for a higher grade does not constitute approval of a lower grade. If it is demonstrated to the satisfaction of the Classification Society that the higher and lower grades are produced to the same manufacturing procedure using the same chemistry and heat treatment, consideration will be given to qualification of a lower grade by a higher. The parameters applied during qualification are not to be modified during production.

Note:

1. This UR is to be uniformly implemented by IACS Societies on offshore units and single point moorings contracted for construction on or after 1 July 2011 and when the application for certification of mooring chains and accessories is dated on or after 1 July 2011.
2. Rev.6 of this UR is to be uniformly implemented by IACS Societies on offshore units and single point moorings contracted for construction on or after 1 July 2017 and when the application for certification of mooring chains and accessories is dated on or after 1 July 2017.
3. The “contracted for construction” date means the date on which the contract to build the vessel is signed between the prospective owner and the shipbuilder. For further details regarding the date of “contract for construction”, refer to IACS Procedural Requirement (PR) No. 29.

W22 (cont)

1.3 Approval of chain manufacturers

1.3.1 Offshore mooring chains are to be manufactured only by works approved by the Classification Society. For this purpose approval tests are to be carried out, the scope of which is to include proof and breaking load tests, measurements and mechanical tests including fracture mechanics tests.

1.3.2 Manufacturers are to submit for review and approval the sequence of operations from receiving inspection to shipment and details of the following manufacturing processes:

- a) Bar heating and bending including method, temperatures, temperature control and recording,
- b) Flash welding including current, force, time and dimensional variables as well as control and recording of parameters, maintenance procedure and programme for welding machine,
- c) Flash removal including method and inspection,
- d) Stud insertion method, for stud link chain,
- e) Heat treatment including furnace types, means of specifying, controlling and recording of temperature and chain speed and allowable limits, quenching bath and agitation, cooling method after exit,
- f) Proof and break loading including method/machine, means of horizontal support (if applicable), method of measurement and recording,
- g) Non-destructive examination procedures,
- h) The manufacturer's surface quality requirement of mooring components is to be submitted.
- i) The manufacturer's procedure for removing and replacing defective links without heat treatment of the entire chain.

1.3.3 For initial approval CTOD tests are to be carried out on the particular IACS mooring grade of material. CTOD tests are to be tested in accordance with a recognized standard such as BS 7448 Part 1 & BS EN ISO 15653:2010. The CTOD test piece is to be a standard 2 x 1 single edge notched bend piece, test location as shown in Figure 1. The notch of the CTOD specimen is to be located as close to the surface as practicable. The minimum cross section of the test piece shall be 50 x 25mm for chain diameters less than 120mm, and 80 x 40mm for diameters 120mm and above. CTOD specimens are to be taken from both the side of the link containing the weld and from the opposite side. Three links are to be selected for testing, a total of six CTOD specimens. The tests are to be taken at minus 20° C and the lowest CTOD of each set of 3 specimens shall meet the minimum values indicated below in table 1:

Table 1 Minimum CTOD test values for chain type

Chain Type	R3 in mm		R3S in mm		R4 in mm		R4S & R5 in mm	
	BM	WM	BM	WM	BM	WM	BM	WM
Stud link	0.20	0.10	0.22	0.11	0.24	0.12	0.26	0.13
Studless	0.20	0.14	0.22	0.15	0.24	0.16	0.26	0.17

1.3.4 Calibration of furnaces shall be verified by measurement and recording of a calibration test piece with dimensions equivalent to the maximum size of link manufactured. The manufacturer shall submit a procedure for furnace temperature surveys which shall include the following requirements: The temperature uniformity of furnaces is to be surveyed whenever approval of manufacturer is requested and at least annually during normal operating conditions. Furnaces are to be checked by conveying a monitoring link instrumented with two thermocouples through the furnaces at representative travel speed.

W22 (cont)

One thermocouple shall be attached to the surface of the straight part and one thermocouple shall be imbedded in a drilled hole located at the mid thickness position of the straight part of the calibration block. The time-temperature curves shall show that the temperatures throughout the cross section and the soaking times are within specified limits as given in the heat treatment procedure.

1.3.5 For R4S and R5 chain and accessories, prior to approval, the manufacturer is to have undertaken experimental tests or have relevant supporting data to develop the chain and accessory material. The tests and data may include: fatigue tests, hot ductility tests (no internal flaws are to develop whilst bending in the link forming temperature range), welding parameter research, heat treatment study, strain age resistance, temper embrittlement study, stress corrosion cracking (SCC) data and hydrogen embrittlement (HE) study, using slow strain test pieces in hydrated environments. Reports indicating the results of experimental tests are to be submitted.

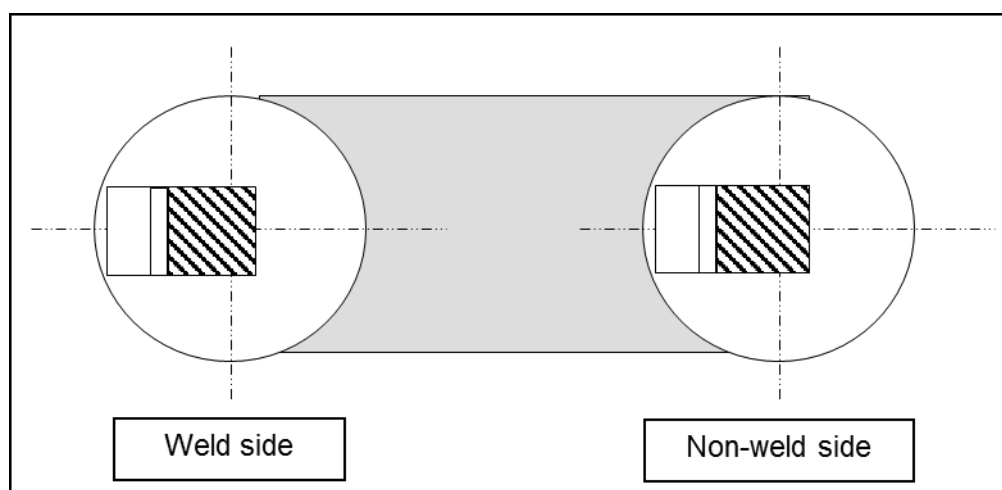

Figure 1 Location of CTOD test specimens for chain

1.4 Approval of quality system at chain and accessory manufacturers

1.4.1 Chain and accessory manufacturers are to have a documented and effective quality system approved by the Classification Society. The provision of such a quality system is required in addition to, and not in lieu of, the witnessing of tests by a Surveyor as specified in Sections 2 to 5 of this Unified Requirement.

1.5 Approval of steel mills; Rolled Bar

1.5.1 Bar materials intended for chain and accessories are to be manufactured only by works approved by the Classification Society. The approval is limited to a nominated supplier of bar material. If a chain manufacturer wishes to use material from a number of suppliers, separate approval tests must be carried out for each supplier.

1.5.2 Approval will be given only after successful testing of the completed chain. Each Grade is to be individually approved. Approval for a higher grade does not constitute approval of a lower grade. If it is demonstrated to the satisfaction of the Classification Society that the higher and lower grades are produced to the same manufacturing procedure using the same

W22
(cont)

chemistry and heat treatment, consideration will be given to qualification of a lower grade by a higher. The parameters applied during qualification are not to be modified during production. The approval will normally be limited up to the maximum diameter equal to that of the chain diameter tested. The rolling reduction ratio is to be recorded and is to be at least 5:1 for R3, R3S, R4, R4S and R5. The rolling reduction ratio used in production can be higher, but should not be lower than that qualified.

1.5.3 The steelmaker is to submit a specification of the chemical composition of the bar material, which must be approved by the Classification Society and by the chain manufacturer. The steel maker is to confirm by analysis and testing that the specification is met. For Grade R4, R4S and R5 chain the steel shall contain a minimum of 0.20 per cent molybdenum.

1.5.4 A heat treatment sensitivity study simulating chain production conditions shall be applied in order to verify mechanical properties and establish limits for temperature and time combinations. All test details and results are to be submitted to the Classification Society.

1.5.5 The bar manufacturer is to provide evidence that the manufacturing process produces material that is resistant to strain ageing, temper embrittlement and for R3S, R4, R4S and R5, hydrogen embrittlement. All test details and results are to be submitted to the Classification Society.

1.6 Approval of forges and foundries; Accessories

1.6.1 Forges and foundries intending to supply finished or semi-finished accessories are to be approved by the Classification Society. A description of manufacturing processes and process controls is to be submitted to the Classification Society. The scope of approval is to be agreed with the Classification Society. The approval is to be limited to a nominated supplier of forged or cast material. If an accessory manufacturer wishes to use material from a number of suppliers, a separate approval must be carried out for each supplier.

1.6.2 Approval will be given only after successful testing of the completed accessory. Approval for a higher grade does not constitute approval of a lower grade. If it is demonstrated to the satisfaction of the Classification Society that the higher and lower grades are produced to the same manufacturing procedure using the same steel specification, supplier and heat treatment, consideration will be given to qualification of a lower grade by a higher. The approval will normally be limited to the type of accessory and the IACS designated mooring grade of material up to the maximum diameter or thickness equal to that of the completed accessory used for qualification unless otherwise agreed by the Classification Society. However for the different accessories that have the same geometry, the tests for initial approval are to be carried out on the one having the lowest reduction ratio. Qualification of accessory pins to maximum diameters is also required. Individual accessories of complex geometries will be subject to the Classification Society requirements.

1.6.3 For forgings – Forgings are to have wrought microstructure and the minimum reduction ratio is to be 3 to 1. The forging reduction ratio, used in the qualification tests, from cast ingot/slab to forged component is to be recorded. The forging reduction ratio used in production can be higher, but should not be lower than that qualified. The degree of upsetting during qualification is to be recorded and maintained during production. Heat cycling during forging and reheating is to be monitored by the manufacturer and recorded in the forging documentation. The manufacturer is to have a maintenance procedure and schedule for dies and tooling which shall be submitted to the Classification Society.

W22 (cont)

1.6.4 The forge or foundry is to submit a specification of the chemical composition of the forged or cast material, which must be approved by the Classification Society. For Grade R4, R4S and R5 chain the steel should contain a minimum of 0.20 per cent molybdenum.

1.6.5 Forges and foundries are to provide evidence that the manufacturing process produces material that is resistant to strain ageing, temper embrittlement and for R4S and R5 grades, hydrogen embrittlement. A heat treatment sensitivity study simulating accessory production conditions shall be applied in order to verify mechanical properties and establish limits for temperature and time combinations. (Cooling after tempering shall be appropriate to avoid temper embrittlement). All test details and results are to be submitted to the Classification Society.

1.6.6 For initial approval CTOD tests are to be carried out on the particular IACS mooring grade of material. Three CTOD tests are to be tested in accordance with a recognized standard such as BS 7448 Part 1 & BS EN ISO 15653:2010. For rectangular accessories, the CTOD test piece is to be a standard 2 x 1 single edge notched bend specimen of thickness equal to full thickness of material to be tested. Sub-sized specimens can be used subject to approval of the Classification Society. For circular geometries, the minimum cross section of the test piece shall be 50 x 25mm for accessory diameters less than 120mm, and 80 x 40mm for diameters 120mm and above. The notch of the CTOD specimen is to be located as close to the surface as practicable. The tests are to be taken at minus 20° C and the results submitted for review. The minimum values of each set of three specimens are to at least meet the requirements as indicated in table 2 (same as that of the studless chain material shown in table 1).

Table 2 Minimum CTOD test values for accessories

<i>Grade of Accessory</i>	<i>R3 in mm</i>	<i>R3S in mm</i>	<i>R4 in mm</i>	<i>R4S & R5 in mm</i>
CTOD	0.20	0.22	0.24	0.26

The geometry of accessories can vary. Figure 2 shows the CTOD location for circular and rectangular cross sections such as those of the D-shackle and accessories fabricated from rectangular sections. The orientation of the specimen shall consider the direction of the grain flow. Figure 2(b) shows two possible sampling positions for CTOD test specimens with notch orientation for rectangular type accessories.

W22 (cont)

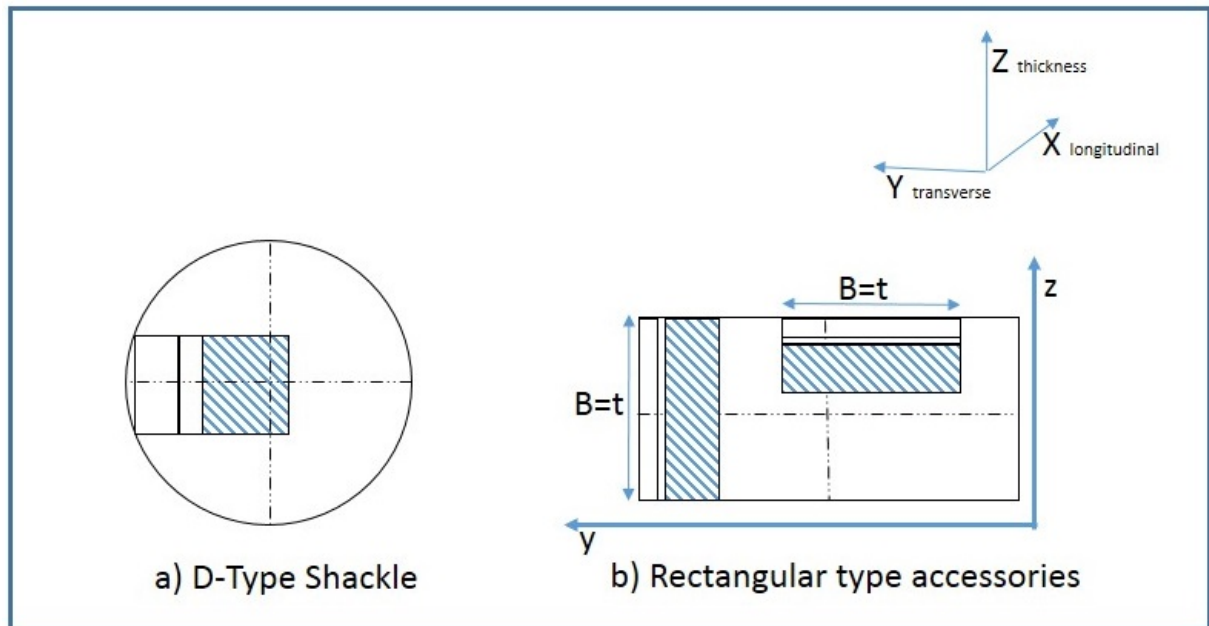

Figure 2 Location of CTOD test specimens: a) Circular type accessory and b) rectangular type accessory, B corresponds to the thickness of material, the grain flow is considered in the longitudinal direction X

1.6.7 Calibration of furnaces shall be verified by measurement and recording of a calibration test piece with dimensions equivalent to the maximum size of link manufactured. Thermocouples are to be placed both on the surface and in a drilled hole located to the mid thickness position of the calibration block. The furnace dimensions shall be such as to allow the whole furnace charge to be uniformly heated to the necessary temperature. Temperature uniformity surveys of heat treatment furnaces for forged and cast components shall be carried out according to API Spec 6A/ISO 10423 Annex M or ASTM A991. The initial survey shall be carried out with maximum charge (load) in the furnace. Subsequent surveys shall be carried out annually and may be carried out with no furnace charge.

The quench bath maximum temperature and the maximum heat treatment transfer times from furnace to quench are to be established and documented. During production the established quenching parameters are to be followed and records are to be maintained of bath temperatures and transfer times.

1.6.8 For R4S and R5 refer to additional requirements in 1.3.5.

1.7 Approval of quality system at accessory manufacturers

1.7.1 Refer to 1.4.

W22
(cont)**2 MATERIALS****2.1 Scope**

2.1.1 These requirements apply to rolled steels, forgings and castings used for the manufacture of offshore mooring chain and accessories.

2.2 Rolled steel bars**2.2.1 Steel manufacture**

2.2.1.1 The steels are to be manufactured by basic oxygen, electric furnace or such other process as may be specially approved. All steels are to be killed and fine grain treated. The austenitic grain size for R3, R3S and R4 is to be 6 or finer in accordance with ASTM E112 or equivalent grain size index in accordance to ISO 643. Measurements for circular sections are to be taken at 1/3 radius.

2.2.1.2 Steel for bars intended for R4S and R5 chain is to be vacuum degassed. The austenitic grain size is to be 6 or finer in accordance with ASTM E112 or equivalent grain size index in accordance to ISO 643. Measurements for circular sections are to be taken at 1/3 radius.

2.2.1.3 For R4S and R5 the following information is to be supplied by the bar manufacturer to the mooring chain manufacturer and the results included in the chain documentation:

- a) Each heat is to be examined for non-metallic inclusions. The level of micro inclusions is to be quantified and assessed in accordance to the national/international standards; to be sure inclusion levels are acceptable for the final product.
- b) A sample from each heat is to be macro etched according to ASTM E381 or equivalent, to be sure there is no injurious segregation or porosity.
- c) Hardenability data, according to ASTM A255, or equivalent, is to be supplied with each heat.

2.2.2 Chemical composition

2.2.2.1 For acceptance tests, the chemical composition of ladle samples of each heat is to be determined by the steel maker and is to comply with the approved specification.

2.2.3 Mechanical tests

2.2.3.1 Bars of the same nominal diameter are to be presented for test in batches of 50 tonnes or fraction thereof from the same heat. Test specimens are to be taken from material heat treated in the same manner as intended for the finished chain.

2.2.3.2 Each heat of Grade R3S, R4, R4S and R5 is to be tested for hydrogen embrittlement. In case of continuous casting, test samples representing both the beginning and the end of the charge shall be taken. In case of ingot casting, test samples representing two different ingots shall be taken.

2.2.3.2.1 Two (2) tensile test specimens shall be taken from the central region of bar material which has been subjected to the heat treatment cycle intended to be used in production. A specimen with a diameter of 20 mm is preferred (consideration will be given to a diameter of 14 mm).

W22 (cont)

2.2.3.2.2 One of the specimens is to be tested within a maximum of 3 hours after machining (for a 14 mm diameter specimen, the time limit is 1½ hours). Where this is not possible, the specimen is to be immediately cooled to -60°C after machining and kept at that temperature for a maximum period of 5 days.

2.2.3.2.3 The second specimen is to be tested after baking at 250°C for 4 hours, alternatively 2 hours for 14 mm diameter specimen.

2.2.3.2.4 A slow strain rate $< 0,0003 \text{ s}^{-1}$ must be used during the entire test, until fracture occurs (This is approximately 10 minutes for the 20 mm diameter specimen). Tensile strength, elongation and reduction of area are to be reported.

2.2.3.2.5 The acceptance requirement for the test is:

$$Z_1/Z_2 \geq 0.85$$

where:

Z_1 = Reduction of area without baking

Z_2 = Reduction of area after baking

If the requirement $Z_1/Z_2 \geq 0.85$ is not achieved, the bar material may be subjected to a hydrogen degassing treatment after agreement with the Classification Society. New tests shall be performed after degassing.

2.2.3.3 For all grades, one tensile and three Charpy V-notch specimens are to be taken from each sample selected. The test specimens are to be taken at approx. one-third radius below the surface, as shown in Figure 3 and prepared in accordance with UR W2. The results of all tests are to be in accordance with the appropriate requirements of Table 3.

2.2.3.4 Re-test requirements for tensile and Charpy impact tests are detailed in UR W2.

2.2.3.5 Failure to meet the requirements will result in rejection of the batch represented unless it can be clearly attributable to improper simulated heat treatment.

Table 3 Mechanical properties of offshore mooring chain and accessories

Grade	Yield stress N/mm ² minimum (1)	Tensile strength N/mm ² minimum (1)	Elongation % minimum	Reduction (3) of area % minimum	Charpy V-notch impact tests		
					Test temperature °C (2)	Average energy J minimum	Avg. energy flash weld J minimum
R3	410	690	17	50	0	60	50
					-20	40	30
R3S	490	770	15	50	0	65	53
					-20	45	33
R4	580	860	12	50	-20	50	36
R4S ⁽⁴⁾	700	960	12	50	-20	56	40
R5 ⁽⁴⁾	760	1000	12	50	-20	58	42

W22 (cont)

NOTES

1. Aim value of yield to tensile ratio: 0.92 max.
2. At the option of the Classification Society the impact test of Grade R3 and R3S may be carried out at either 0°C or minus 20°C (See Table 3).
3. Reduction of area of cast steel is to be for Grades R3 and R3S: min. 40 %, for R4, R4S and R5: min. 35 %, cf. item 2.4.4.
4. Aim maximum hardness for R4S is HB330 and R5 HB340.

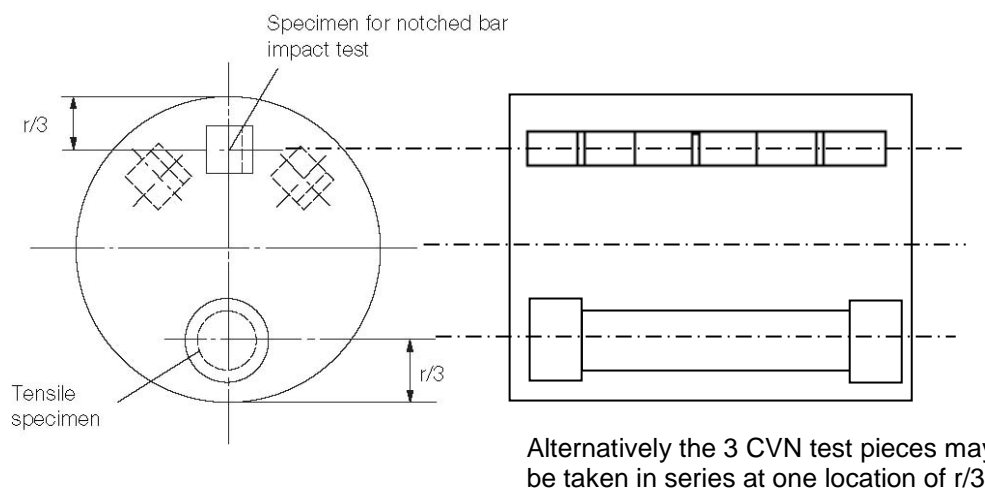

Figure 3 Sampling of steel bars, forgings and castings

2.2.4 Dimensional tolerances

2.2.4.1 The diameter and roundness shall be within the tolerances specified in Table 4, unless otherwise agreed.

Table 4 Dimensional tolerance of bar stock

Nominal diameter mm	Tolerance on diameter mm	Tolerance on roundness ($d_{\max} - d_{\min}$) mm
less than 25	-0 + 1.0	0.6
25 - 35	-0 + 1.2	0.8
36 - 50	-0 + 1.6	1.1
51 - 80	-0 + 2.0	1.5
81 - 100	-0 + 2.6	1.95
101 - 120	-0 + 3.0	2.25
121 - 160	-0 + 4.0	3.00
161 - 222	-0 + 5.0	4.00

W22
(cont)**2.2.5 Non-destructive examination and repair**

2.2.5.1 Non-destructive examination is to be performed in accordance with recognized Standards such as those indicated below or equivalent. Non-destructive examination procedures, together with rejection/acceptance criteria are to be submitted to the Classification Society.

Magnetic particle testing (MT) of bars:

- ASTM E1444 and ISO 9934

Magnetic Leakage Flux Testing (MLFT)-JIS Z2319

Eddy current testing (ET) of bars:

- ISO 15549

2.2.5.2 Manufacturers shall prepare written procedures for NDE. NDE personnel shall be qualified and certified according to ISO 9712, ACCP or equivalent. Personnel qualification to an employer or responsible agency based qualification scheme as SNT-TC-1A may be accepted if the employer's written practice is reviewed and found acceptable and the Level III is ASNT Level III, ISO 9712 Level III or ACCP Professional Level III and certified in the applicable method. NDE operators shall be qualified to at least level II.

2.2.5.3 The manufacturer shall ensure that 100 percent of bar material intended for either chain or fittings is subjected to ultrasonic examination at an appropriate stage of the manufacture to procedures approved by the Classification Society and to the acceptance criteria required. The bars shall be free of pipe, cracks and flakes. If the end length of the delivered bars is not subjected to UT then it must be agreed between the bar supplier and the chain manufacturer of what length of bar is to be removed from the ends. The details are to be documented in the approval of each bar supplier. Phased array UT procedures may be applied, subject to approval by the Classification Society.

2.2.5.4 100 percent of the bar material is to be examined by magnetic particle (MT) or eddy current (ET) or Magnetic Leakage Flux Testing (MLFT) methods. The bars shall be free of injurious surface imperfections such as seams, laps and rolled-in mill scale. Provided that their depth is not greater than 1% of the bar diameter, longitudinal discontinuities may be removed by grinding and blending to a smooth contour.

All bars supplied in a machined (peeled) condition shall be 100% visually inspected. The Classification Society may also require: 10% inspected with magnetic particle testing (MT) or eddy current testing (ET) or Magnetic Leakage Flux Testing (MLFT), for longitudinal imperfections. The maximum depth of peeling is to be agreed and documented in the approval of each supplier.

2.2.5.5 The frequency of NDE may be reduced at the discretion of the Classification Society provided it is verified by statistical means that the required quality is consistently achieved.

2.2.5.6 Weld repair of bar is not permitted.

2.2.6 Marking

2.2.6.1 Each bar is to be stamped with the steel grade designation and the charge number (or a code indicating the charge number) on one of the end surfaces. Other marking methods may be accepted subject to agreement.

W22
(cont)**2.3 Forged steel****2.3.1 Manufacture**

2.3.1.1 Forged steels used for the manufacture of accessories must be in compliance with approved specifications and the submitted test reports approved by the Classification Society. Steel is to be manufactured by basic oxygen, electric furnace or such other process as may be specially approved. All steel is to be killed and fine grain treated. The austenitic grain size for R3, R3S and R4 is to be 6 or finer in accordance with ASTM E112 or equivalent grain size index in accordance to ISO 643. Measurements for circular sections are to be taken at 1/3 radius. Measurements for non-circular sections are to be taken at 1/4t.

2.3.1.2 Steel for forgings intended for R4S and R5 chain is to be vacuum degassed. The austenitic grain size is to be 6 or finer in accordance with ASTM E112 or equivalent grain size index in accordance to ISO 643. Measurements for circular sections are to be taken at 1/3 radius. Measurements for non-circular sections are to be taken at 1/4t.

2.3.1.3 For steel intended for R4S and R5 accessories the following information is to be supplied by the steel manufacturer to the mooring accessory manufacturer and the results included in the accessory documentation:

- a) Each heat is to be examined for non-metallic inclusions. The level of micro inclusions is to be quantified and assessed in accordance with the national/international standards; to be sure inclusion levels are acceptable for the final product.
- b) A sample from each heat is to be macro-etched according to ASTM E381 or equivalent, to be sure there is no injurious segregation or porosity.
- c) Hardenability data, according to ASTM A255, or equivalent, is to be supplied with each heat.

2.3.2 Chemical composition (See 2.2.2)**2.3.3 Heat treatment**

2.3.3.1 Finished forgings are to be properly heat treated in compliance with specifications submitted and approved.

2.3.4 Mechanical properties

2.3.4.1 The forgings must comply with the mechanical properties given in Table 3, when properly heat treated.

2.3.5 Mechanical tests

2.3.5.1 For test sampling, forgings of similar dimensions (diameters do not differ by more than 25mm) originating from the same heat treatment charge and the same heat of steel are to be combined into one test unit. From each test unit one tensile and three impact test specimens are to be taken and tested in accordance with UR W2. For the location of the test specimens see Figure 3.

2.3.5.2 Each heat of Grade R3S, R4, R4S and R5 is to be tested for hydrogen embrittlement. In case of continuous casting, test samples representing both the beginning and the end of the charge shall be taken. In case of ingot casting, test samples representing two different ingots shall be taken.

W22
(cont)

2.3.5.2.1 Two (2) tensile test specimens shall be taken from the central region of forged material which has been subjected to the heat treatment cycle intended to be used in production. A specimen with a diameter of 20 mm is preferred (consideration will be given to a diameter of 14 mm).

2.3.5.2.2 One of the specimens is to be tested within a maximum of 3 hours after machining (for a 14 mm diameter specimen, the time limit is 1½ hours). Where this is not possible, the specimen is to be immediately cooled to -60°C after machining and kept at that temperature for a maximum period of 5 days.

2.3.5.2.3 The second specimen is to be tested after baking at 250°C for 4 hours, alternatively 2 hours for 14 mm diameter specimen.

2.3.5.2.4 A slow strain rate $< 0,0003 \text{ s}^{-1}$ must be used during the entire test, until fracture occurs (This is approximately 10 minutes for the 20 mm diameter specimen). Tensile strength, elongation and reduction of area are to be reported.

2.3.5.2.5 The acceptance requirement for the test is:

$$Z_1/Z_2 \geq 0.85$$

where:

Z_1 = Reduction of area without baking

Z_2 = Reduction of area after baking

If the requirement $Z_1/Z_2 \geq 0.85$ is not achieved, the bar material may be subjected to a hydrogen degassing treatment after agreement with the Classification Society. New tests shall be performed after degassing.

2.3.6 Non-destructive examination and repair

2.3.6.1 Non-destructive examination is to be performed in accordance with recognized Standards, such as those indicated below, or equivalent. The non-destructive examination procedures, together with rejection/acceptance criteria are to be submitted to the Classification Society.

Magnetic particle testing (MT) of forgings:

- EN 10228-1, ASTM A275, using wet continuous magnetization technique

Ultrasonic testing (UT) of forgings:

- EN 10228-3, ASTM A388, ISO 13588

2.3.6.2 Manufacturers shall prepare written procedures for NDE. NDE personnel shall be qualified and certified according to ISO 9712, ACCP or equivalent. Personnel qualification to an employer or responsible agency based qualification scheme as SNT-TC-1A may be accepted if the employer's written practice is reviewed and found acceptable and the Level III is ASNT Level III, ISO 9712 Level III or ACCP Professional Level III and certified in the applicable method. NDE operators shall be qualified to at least level II.

2.3.6.3 The forgings are to be subjected to one hundred percent ultrasonic examination at an appropriate stage of manufacture and in compliance with the standard submitted and approved.

W22
(cont)

2.3.6.4 Defects on non-machined surfaces may be removed by grinding to a depth of 5% of the nominal diameter. Grinding is not permitted on machined surfaces, except for slight inspection grinding on plane surfaces to a maximum depth of 0.8 mm in order to investigate spurious indications. Welding repairs are not permitted.

2.3.7 Marking

2.3.7.1 Marking is to be similar to that specified in 2.2.6.

2.4 Cast steel**2.4.1 Manufacture**

2.4.1.1 Cast steel used for the manufacture of accessories must be in compliance with approved specifications and the submitted test reports approved by the Classification Society. Steel is to be manufactured by basic oxygen, electric furnace or such other process as may be specially approved. All steel is to be killed and fine grain treated. The austenitic grain size for R3, R3S and R4 is to be 6 or finer in accordance with ASTM E112 or equivalent grain size index in accordance to ISO 643. Measurements for circular sections are to be taken at 1/3 radius. Measurements for non-circular sections are to be taken at 1/4t.

2.4.1.2 Steel for castings intended for R4S and R5 accessories is to be vacuum degassed. The austenitic grain size is to be 6 or finer in accordance with ASTM E112 or equivalent grain size index in accordance to ISO 643. Measurements for circular sections are to be taken at 1/3 radius. Measurements for non-circular sections are to be taken at 1/4t.

2.4.1.3 For steel intended for R4S and R5 accessories the following information is to be obtained and the results included in the accessory documentation:

- a) Each heat is to be examined for non-metallic inclusions. The level of micro inclusions is to be quantified and assessed in accordance to the national/international standards; to be sure inclusion levels are acceptable for the final product.
- b) A sample from each heat is to be macro etched according to ASTM E381 or equivalent, to be sure there is no injurious segregation or porosity.
- c) Hardenability data, according to ASTM A255, or equivalent, is to be supplied with each heat.

2.4.2 Chemical composition (See 2.2.2)**2.4.3 Heat treatment**

2.4.3.1 All castings are to be properly heat treated in compliance with specifications submitted and approved.

2.4.4 Mechanical properties

2.4.4.1 The castings must comply with the mechanical properties given in Table 3. The acceptance requirement for reduction of area is, however, reduced to 40 percent for grades R3 and R3S and 35 percent for grades R4, R4S and R5.

2.4.5 Mechanical tests

2.4.5.1 For test sampling, castings of similar dimensions originating from the same heat treatment charge and the same heat of steel are to be combined into one test unit. From each

W22
(cont)

test unit one tensile and three impact test specimens are to be taken and tested. For the location of the test specimens see Figure 3.

2.4.6 Non-destructive examination and repair

2.4.6.1 Non-destructive examination is to be performed in accordance with recognized standards, such as those indicated below, or equivalent. The non-destructive examination procedures, together with rejection/acceptance criteria are to be submitted to the Classification Society.

Magnetic particle testing (MT) of castings:

- ASTM E709, using wet continuous magnetisation technique

Ultrasonic testing (UT) of castings:

- ASTM A609, ISO 13588

2.4.6.2 Manufacturers shall prepare written procedures for NDE. NDE personnel shall be qualified and certified according to ISO 9712, ACCP or equivalent. Personnel qualification to an employer or responsible agency based qualification scheme as SNT-TC-1A may be accepted if the employer's written practice is reviewed and found acceptable and the Level III is ASNT Level III, ISO 9712 Level III or ACCP Professional Level III and certified in the applicable method. NDE operators shall be qualified to at least level II.

2.4.6.3 The castings are to be subjected to one hundred percent ultrasonic examination in compliance with the standard submitted and approved.

2.4.6.4 Defects on non-machined surfaces may be removed by grinding to a depth of 5% of the nominal diameter. Grinding is not permitted on machined surfaces, except for slight inspection grinding on plane surfaces to a maximum depth of 0.8 mm in order to investigate spurious indications.

2.4.6.5 Where the repair entails removal of more than 5% of the diameter or thickness, the defective area shall be repaired by welding. The excavations shall be suitably shaped to allow good access for welding. The resulting grooves shall be subsequently ground smooth and complete elimination of the defective material shall be verified by NDE.

2.4.6.6 Weld repairs are classified as major or minor. A weld repair is considered major when the depth of the groove prepared for welding exceeds 25% of the diameter/thickness or 25 mm, whichever is smaller. All other weld repairs are considered minor.

2.4.6.7 Major weld repairs require approval before the repair is commenced. Proposals for major repairs shall be accompanied by sketches or photographs showing the extent and positions of the repairs. A grain refining heat treatment shall be given to the whole casting prior to major repairs. A post weld heat treatment or repeat of original heat treatment of castings shall be carried out.

2.4.6.8 Minor and major weld repairs must be recorded on sketches or photographs showing the extent and positions of the repairs.

2.4.6.9 All weld repairs shall be done by qualified welders using qualified procedures. Welders shall be qualified according to ISO 9606, ASME IX, ASTM A488 or equivalent. Procedures shall be qualified according to ISO 15614, ASME IX, ASTM A488 or equivalent with the following additional requirements: Charpy V notch impact tests with notch locations in weld metal, fusion line and heat affected zone + 2 mm and + 5 mm from fusion line, respectively. Test results shall meet the requirements specified for the parent metal.

W22
(cont)

2.4.7 Marking (See 2.3.7)

2.5 Materials for studs

2.5.1 Studs intended for stud link chain cable are to be made of steel corresponding to that of the chain or in compliance with specifications submitted and approved. In general, the carbon content should not exceed 0.25 percent if the studs are to be welded in place.

3 DESIGN AND MANUFACTURE**3.1 Design**

3.1.1 Drawings accompanied by design calculations, giving detailed design of chain and accessories made by or supplied through the chain manufacturer are to be submitted for approval. Typical designs are given in ISO 1704. For studless chain the shape and proportions are to comply with the requirements of this UR. Other studless proportions are to be specially approved. It should be considered that new or non-Standard designs of chain, shackles or fittings, may require a fatigue analysis and possible performance, fatigue or corrosion fatigue testing.

3.1.2 In addition, for stud link chain, drawings showing the detailed design of the stud shall be submitted for information. The stud shall give an impression in the chain link which is sufficiently deep to secure the position of the stud, but the combined effect of shape and depth of the impression shall not cause any harmful notch effect or stress concentration in the chain link.

3.1.3 Machining of Kenter shackles shall result in fillet radius min. 3 percent of nominal diameter.

3.2 Chain cable manufacturing process**3.2.1 General**

3.2.1.1 Offshore mooring chains shall be manufactured in continuous lengths by flash butt welding and are to be heat treated in a continuous furnace; batch heat treatment is not permitted, except in special circumstances where short lengths of chain are delivered, such as chafing chain. Ref. Appendix A.

3.2.1.2 The use of joining shackles to replace defective links is subject to the written approval of the end purchaser in terms of the number and type permitted. The use of connecting common links is restricted to 3 links in each 100m of chain.

3.2.2 Chain cable manufacturing process records

3.2.2.1 Records of bar heating, flash welding and heat treatment shall be made available for inspection by the Surveyor.

3.2.3 Bar heating

3.2.3.1 Bars for links shall be heated by electric resistance, induction or in a furnace.

3.2.3.2 For electric resistance heating or induction heating, the heating phase shall be controlled by an optical heat sensor. The controller shall be checked at least once every 8 hours and records made.

3.2.3.3 For furnace heating, the heat shall be controlled and the temperature continuously recorded using thermocouples in close proximity to the bars. The controls shall be checked at least once every 8 hours and records made.

3.2.4 Flash welding of chain cable

3.2.4.1 The following welding parameters shall be controlled during welding of each link:

- a) Platen motion

W22 (cont)

- b) Current as a function of time
- c) Hydraulic pressure

3.2.4.2 The controls shall be checked at least every 4 hours and records made.

3.2.5 Heat treatment of chain cable

3.2.5.1 Chain shall be austenitized, above the upper transformation temperature, at a combination of temperature and time within the limits established.

3.2.5.2 When applicable, chain shall be tempered at a combination of temperature and time within the limits established. Cooling after tempering shall be appropriate to avoid temper embrittlement.

3.2.5.3 Temperature and time or temperature and chain speed shall be controlled and continuously recorded.

3.2.5.4 Grain determination shall be made for the final product. The austenitic grain size for R3, R3S, R4, R4S and R5 is to be 6 or finer in accordance with ASTM E112 or equivalent grain size index in accordance to ISO 643. Measurements for circular sections are to be taken at surface, 1/3 radius and centre for the base material, HAZ and weld.

3.2.6 Mechanical properties

3.2.6.1 The mechanical properties of finished chain and accessories are to be in accordance with Table 3. For the location of test specimens see Figures 3 and 4.

3.2.7 Proof and breaking test loads

3.2.7.1 Chains and accessories are to withstand the proof and break test loads given in Table 5.

3.2.8 Freedom from defects

3.2.8.1 All chains are to have a workmanlike finish consistent with the method of manufacture and be free from defects. Each link is to be examined in accordance with section 4.5 using approved procedures.

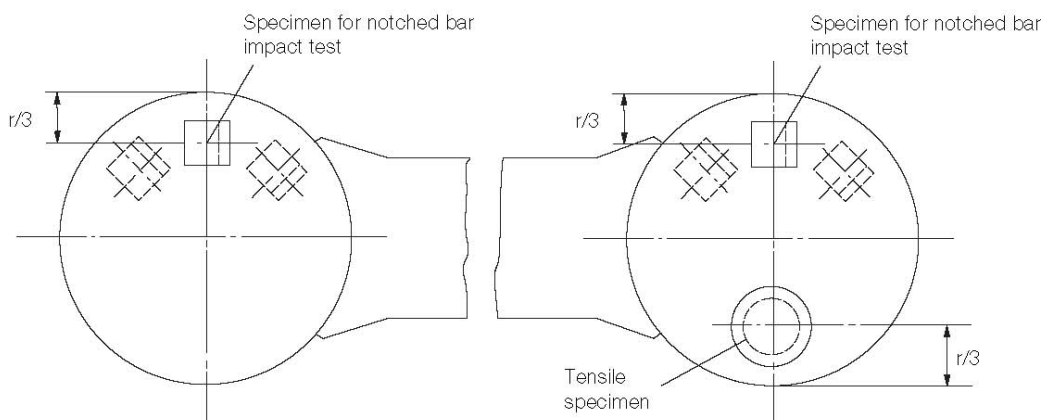

Figure 4 Sampling of chain links

W22

(cont)

Table 5 Formulas for proof and break test loads, weight and length over 5 links

<i>Test Load, in kN</i>	<i>Grade R3 Stud Link</i>	<i>Grade R3S Stud Link</i>	<i>Grade R4 Stud Link</i>	<i>Grade R4S Stud Link</i>	<i>Grade R5 Stud Link</i>
Proof	$0.0148 d^2$ ($44 - 0.08d$)	$0.0180 d^2$ ($44 - 0.08d$)	$0.0216 d^2$ ($44 - 0.08d$)	$0.0240 d^2$ ($44 - 0.08d$)	$0.0251 d^2$ ($44 - 0.08d$)
Break	$0.0223 d^2$ ($44 - 0.08d$)	$0.0249 d^2$ ($44 - 0.08d$)	$0.0274 d^2$ ($44 - 0.08d$)	$0.0304 d^2$ ($44 - 0.08d$)	$0.0320 d^2$ ($44 - 0.08d$)
<i>Test Load, in kN</i>	<i>Grade R3 Studless</i>	<i>Grade R3S Studless</i>	<i>Grade R4 Studless</i>	<i>Grade R4S Studless</i>	<i>Grade R5 Studless</i>
Proof	$0.0148 d^2$ ($44 - 0.08d$)	$0.0174 d^2$ ($44 - 0.08d$)	$0.0192 d^2$ ($44 - 0.08d$)	$0.0213 d^2$ ($44 - 0.08d$)	$0.0223 d^2$ ($44 - 0.08d$)
Break	$0.0223 d^2$ ($44 - 0.08d$)	$0.0249 d^2$ ($44 - 0.08d$)	$0.0274 d^2$ ($44 - 0.08d$)	$0.0304 d^2$ ($44 - 0.08d$)	$0.0320 d^2$ ($44 - 0.08d$)
Chain Weight, in kg/m	Stud link = $0.0219d^2$				
Chain Weight, in kg/m	Studless chain Weight calculations for each design are to be submitted.				
Pitch Length	Five Link Measure				
Minimum	$22d$				
Maximum	$22.55d$				

3.2.9 Dimensions and dimensional tolerances

3.2.9.1 The shape and proportion of links and accessories must conform to ISO 1704 or the designs specially approved.

3.2.9.2 The following tolerances are applicable to links:

a) The negative tolerance on the nominal diameter measured at the crown:

up to 40 mm nominal diameter	: - 1 mm
over 40 up to 84 mm nominal diameter	: - 2 mm
over 84 up to 122 mm nominal diameter	: - 3 mm
over 122 up to 152 mm nominal diameter	: - 4 mm
over 152 up to 184 mm nominal diameter	: - 6 mm
over 184 up to 222 mm nominal diameter	: - 7.5 mm

Note 1:

The cross sectional area at the crown must have no negative tolerance. For diameters of 20 mm or greater, the plus tolerance may be up to 5 percent of the nominal diameter. For diameters less than 20 mm the plus tolerance is to be agreed with the Classification Society at the time of approval.

Note 2:

The cross sectional area at the crown is to be calculated using the average of the diameters with negative tolerance and plus tolerance, measurements are to be taken from at least 2 locations approximately 90 degrees apart.

b) Diameter measured at locations other than the crown:

The diameter is to have no negative tolerance. The plus tolerance may be up to 5 percent of the nominal diameter except at the butt weld where it is to be in accordance

W22 (cont)

to manufacturer's specification, which is to be agreed with the Classification Society. For diameters less than 20 mm, the plus tolerance is to be agreed with the Classification Society at the time of approval.

- c) The allowable manufacturing tolerance on a length of five links is + 2.5 percent, but may not be negative.
- d) All other dimensions are subject to a manufacturing tolerance of ± 2.5 percent, provided always that all parts fit together properly.
- e) The tolerances for stud link and studless common links are to be measured in accordance with Figure 5.
- f) For stud link chains studs must be located in the links centrally and at right angles to the sides of the link. The following tolerances in Figure 5 are acceptable provided that the stud fits snugly and its ends lie flush against the inside of the link:

(a) Stud link - The internal link radii (R) and external radii should be uniform

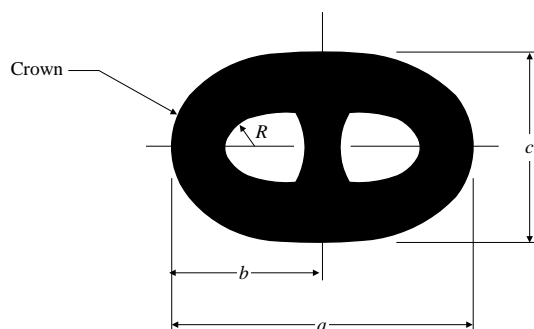

<i>Designation</i> ⁽¹⁾	<i>Description</i>	<i>Nominal Dimension of the Link</i>	<i>Minus Tolerance</i>	<i>Plus Tolerance</i>
<i>a</i>	Link Length	$6d$	$0.15d$	$0.15d$
<i>b</i>	Link Half Length	$a^*/2$	$0.1d$	$0.1d$
<i>c</i>	Link Width	$3.6d$	$0.09d$	$0.09d$
<i>e</i>	Stud Angular Misalignment	0 degrees	4 degrees	4 degrees
<i>R</i>	Inner Radius	$0.65d$	0	-----

Note 1: Dimension designation is shown in above figure
 d = Nominal diameter of chain, a^* = Actual link length

W22 (cont)

(b) **Studless** - The internal link radii (R) and external radii should be uniform.

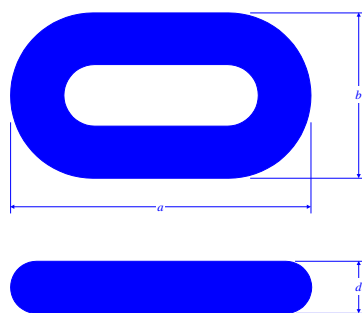

<i>Designation</i> ⁽¹⁾	<i>Description</i>	<i>Nominal Dimension of the Link</i>	<i>Minus Tolerance</i>	<i>Plus Tolerance</i>
a	Link Length	$6d$	$0.15d$	$0.15d$
b	Link Width	$3.35d$	$0.09d$	$0.09d$
R	Inner Radius	$0.60d$	0	-----

- Notes: 1 Dimension designation is shown in above figure.
 d = Nominal diameter of chain
 2 Other dimension ratios are subject to special approval.

Figure 5 (a) Stud link and (b) studless common link, proportions dimensions and tolerances

3.2.10 Stud link chain - welding of studs

3.2.10.1 A welded stud may be accepted for grade R3 and R3S chains. Welding of studs in grades R4, R4S and R5 chain is not permitted unless specially approved.

3.2.10.2 Where studs are welded into the links this is to be completed before the chain is heat treated.

3.2.10.3 The stud ends must be a good fit inside the link and the weld is to be confined to the stud end opposite to the flash butt weld. The full periphery of the stud end is to be welded unless otherwise approved.

3.2.10.4 Welding of studs both ends is not permitted unless specially approved.

3.2.10.5 The welds are to be made by qualified welders using an approved procedure and low-hydrogen approved consumables.

3.2.10.6 The size of the fillet weld shall as a minimum be as per API Specification 2F.

3.2.10.7 The welds are to be of good quality and free from defects such as cracks, lack of fusion, gross porosity and undercuts exceeding 1 mm.

3.2.10.8 All stud welds shall be visually examined. At least 10 per cent of all stud welds within each length of chain shall be examined by dye penetrant or magnetic particles after proof testing. If cracks or lack of fusion are found, all stud welds in that length are to be examined.

W22
(cont)**3.2.11 Connecting common links (splice links)**

3.2.11.1 Single links to substitute for test links or defective links without the necessity for re-heat treatment of the whole length are to be made in accordance with an approved procedure. Separate approvals are required for each grade of chain and the tests are to be made on the maximum size of chain for which approval is sought.

3.2.11.2 Manufacture and heat treatment of connecting common link is not to affect the properties of the adjoining links. The temperature reached by these links is nowhere to exceed 250°C.

3.2.11.3 Each link is to be subjected to the appropriate proof load and non-destructive examination as detailed in Table 5 and Section 4.5. A second link shall be made identical to the connecting common link; the link shall be tested and inspected per Section 4.4 and 4.5.

3.2.11.4 Each connecting common link is to be marked either; on the stud for stud link chain or, on the outer straight length on the side opposite the flash butt weld for studless chain. This marking is to be in accordance with Section 4.7 plus a unique number for the link. The adjoining links are also to be marked on the studs or straight length as above.

4 TESTING AND INSPECTION OF FINISHED CHAIN**4.1 General**

4.1.1 This section applies to but is not limited to finished chain cable such as common stud and studless links, end links, enlarged end links and connecting common links (splice links).

4.1.2 All chain is to be subjected to proof load tests, sample break load tests and sample mechanical tests after final heat treatment in the presence of a Surveyor. Where the manufacturer has a procedure to record proof loads and the Surveyor is satisfied with the adequacy of the recording system, he need not witness all proof load tests. The Surveyor is to satisfy himself that the testing machines are calibrated and maintained in a satisfactory condition. Prior to inspection the chain is to be free from scale, paint or other coating and is to have a suitably prepared surface as per the applied NDE testing standard. The chain shall be sand or shot blast to meet this requirement.

4.2 Proof and break load tests

4.2.1 The entire length of chain shall withstand the proof load specified in Table 5 without fracture and shall not crack in the flash weld. The load applied shall not exceed the proof load by more than 10% when stretching the chain. Where plastic straining is used to set studs, the applied load is not to be greater than that qualified in approval tests.

4.2.2 A break-test specimen consisting of at least 3 links is to be either taken from the chain or produced at the same time and in the same manner as the chain. The test frequency is to be based on tests at sampling intervals according to Table 6 provided that every cast is represented. Each specimen shall be capable of withstanding the break load specified without fracture and shall not crack in the flash weld. It shall be considered acceptable if the specimen is loaded to the specified value and maintained at that load for 30 seconds.

4.2.3 For chain diameters over 100mm, alternative break-test proposals to the above break-test will be considered whereby a one link specimen is used. Alternatives are to be approved by the Classification Society, every heat is to be represented, the test frequency is to be in accordance with Table 6, and it is to be demonstrated and proven that the alternative test represents an equivalent load application to the three link test.

4.2.4 If the loading capacity of the testing machine is insufficient, an alternative load testing machine is to be used that does have sufficient capacity (e.g. two loading machines in parallel) provided the testing and calibration procedure are agreed with the Classification Society.

W22 (cont)

Table 6 Frequency of break and mechanical tests

Nominal chain diameter (mm)	Maximum sampling interval (m)
Min - 48	91
49 - 60	110
61 - 73	131
74 - 85	152
86 - 98	175
99 - 111	198
112 - 124	222
125 - 137	250
138 - 149	274
150 - 162	297
163 - 175	322
176 – 186	346
187 - 198	370
199 - 210	395
211 - 222	420

4.3 Dimensions and dimensional tolerances

4.3.1 After proof load testing measurements are to be taken on at least 5 per cent of the links in accordance with Section 3.2.9.

4.3.2 The entire chain is to be checked for the length, five links at a time. By the five link check the first five links shall be measured. From the next set of five links, at least two links from the previous five links set shall be included. This procedure is to be followed for the entire chain length. The measurements are to be taken preferably while the chain is loaded to 5 - 10 % of the minimum proof load. The tolerances for the 5 link measurements are indicated in Table 5, any deviations from the 5 link tolerances are to be agreed by the client and Classification Society. The links held in the end blocks may be excluded from this measurement.

4.3.3 Chain dimensions are to be recorded and the information retained on file.

4.4 Mechanical tests

4.4.1 Links of samples detached from finished, heat treated chain shall be sectioned for determination of mechanical properties. A test unit shall consist of one tensile and nine impact specimens. The tensile specimen shall be taken in the side opposite the flash weld. Three impact specimens shall be taken across the flash weld with the notch centred in the middle. Three impact specimens shall be taken across the unwelded side and three impact specimens shall be taken from the bend region.

4.4.2 The test frequency is to be based on tests at sampling intervals according to Table 6 provided that every cast is represented. Mechanical properties shall be as specified in Table 3.

W22
(cont)

4.4.3 The frequency of impact testing in the bend may be reduced at the discretion of the Classification Society provided it is verified by statistical means that the required toughness is consistently achieved.

4.4.4 Hardness tests are to be carried out on finished chain. The frequency and locations are to be agreed with the Classification Society. The recorded values are for information only and used as an additional check to verify that the heat treatment process has been stable during the chain production.

4.5 Non-destructive examination after proof load testing

4.5.1 All surfaces of every link shall be visually examined. Burrs, irregularities and rough edges shall be contour ground. Links shall be free from mill defects, surface cracks, dents and cuts, especially in the vicinity where gripped by clamping dies during flash welding. Studs shall be securely fastened. Chain is to be positioned in order to have good access to all surfaces. In order to allow optimal access to the surface area it is recommended that chain be hung in the vertical position, however access to inspect the interlink area may only be possible with the chain in the horizontal position.

4.5.2 Testing is to be performed in accordance with a recognized Standard and the procedures, together with acceptance/rejection criteria are to be submitted to the Classification Society for review. Manufacturers shall prepare written procedures for NDE. NDE personnel shall be qualified and certified according to ISO 9712, ACCP or equivalent. Personnel qualification to an employer or responsible agency based qualification scheme as SNT-TC-1A may be accepted if the employer's written practice is reviewed and found acceptable and the Level III is ASNT Level III, ISO 9712 Level III or ACCP Professional Level III and certified in the applicable method. NDE operators shall be qualified to at least level II.

4.5.3 Magnetic particles shall be employed to examine the flash welded area including the area gripped by the clamping dies. Procedures are to be submitted to the Classification Society for approval. Procedures and equipment in accordance with those approved shall be used. Frequency of examination shall be every link. Additionally, 10% of links are to be tested on all accessible surfaces. Link surfaces and the surface at the flash weld shall be free from cracks, lack of fusion and gross porosity. Testing shall be performed in accordance with ASTM E709 or another recognized standard (e.g. ISO 9934) using wet continuous fluorescent magnetization technique. Non fluorescent techniques can be accepted in special cases where the standard inspection procedures are impractical.

Links shall be free from:

- relevant linear indications exceeding 1.6 mm in transverse direction
- relevant linear indications exceeding 3.2 mm in longitudinal direction
- relevant non-linear indications exceeding 4.8 mm.

4.5.4 Ultrasonics shall be employed to examine the flash weld fusion. Procedures are to be submitted to the Classification Society for approval. Procedures and equipment in accordance with those approved shall be used. On-site calibration standards for chain configurations shall be approved. Frequency of examination shall be every link. The flash weld shall be free from defects causing ultrasonic back reflections equal to or greater than the calibration standard. The flash butt welds shall be ultrasonic tested (UT) in accordance with ASTM E587 or another recognized standard using single probe, angle-beam shear waves in the range from 45 to 70°.

Single probe technique has limitations as far as testing of the central region is concerned and the flash weld imperfections such as flat spots may have poor reflectivity. Where it is deemed

W22
(cont)

necessary, detectability of imperfections may need to be carried out by using a tandem technique, TOFD or phased array.

4.5.5 Stud welds, if used, shall be visually inspected. The toes of the fillets shall have a smooth transition to the link with no undercuts exceeding 1.0 mm. Additionally, at least 10% of the stud welds distributed through the length shall be dye penetrant tested according to ASTM E1417 or magnetic particle tested according to ASTM E1444 or equivalent. Cracks, lack of fusion or gross porosity are not acceptable. If defects are found, testing shall be extended to all stud welds in that length.

4.6 Retest, rejection and repair criteria

4.6.1 If the length over 5 links is short, the chain may be stretched by loading above the proof test load specified provided that the applied load is not greater than that approved and that only random lengths of the chain need stretching. If the length exceeds the specified tolerance, the over length chain links shall be cut out and 4.6.2 shall apply.

4.6.2 If single links are found to be defective or do not meet other applicable requirements, defective links may be cut out and a connecting common link inserted in their place. The individual heat treatment and inspection procedure of connecting common links is subject to the Classification Society's approval. Other methods for repair are subject to the written approval of the Classification Society and the end purchaser. Weld repair of chain is not permitted.

4.6.3 If a crack, cut or defect in the flash weld is found by visual or magnetic particle examination, it shall be ground down no more than 5% of the link diameter in depth and streamlined to provide no sharp contours. The final dimensions must still conform to the agreed standard.

4.6.4 If indications of interior of flash weld defects, in reference to the accepted calibration standards are detected during ultrasonic examination, 4.6.2 shall apply.

4.6.5 If link diameter, length, width and stud alignment do not conform to the required dimensions, these shall be compared to the dimensions of 40 more links; 20 on each side of the affected link. If a single particular dimension fails to meet the required dimensional tolerance in more than 2 of the sample links, all links shall be examined. Sec. 4.6.2 shall apply.

4.6.6 If a break load test fails, a thorough examination with the Surveyor informed in a timely manner is to be carried out to identify the cause of failure. Two additional break test specimens representing the same sampling length of chain are to be subjected to the break load test. Based upon satisfactory results of the additional tests and the results of the failure investigation, it will be decided what lengths of chain can be accepted. Failure of either or both additional tests will result in rejection of the sampling length of chain represented and 4.6.2 shall apply.

4.6.7 If a link fails during proof load testing, a thorough examination with the Surveyor informed in a timely manner is to be carried out to identify the probable cause of failure of the proof test. In the event that two or more links in the proof loaded length fail, that section of proof loaded length is to be rejected. The above failure investigation is to be carried out especially with regard to the presence in other lengths of factors or conditions thought to be causal to failure.

4.6.8 In addition to the above failure investigation, a break test specimen is to be taken from each side of the one failed link, and subjected to the breaking test. Where multiple chains are

W22
(cont)

produced simultaneously it is recognised that the preceding flash butt welded link and subsequent flash butt welded link will be on an alternative chain length or the other end of the chain length. In such cases the Classification Society may require that two additional break tests are to be taken from the lengths of chain that include the preceding and subsequent welded links. Based upon satisfactory results of both break tests and the results of the failure investigation, it will be decided what length of chain can be considered for acceptance. Failure of either or both breaking tests will result in rejection of the same proof loaded length. Replacement of defective links is to be in accordance with 4.6.2.

If the investigation identifies defects in the flash butt weld or a lower strength flash weld "a glue-weld" is found, additional NDT such as phased array UT is to be carried out to identify if other links are affected. A full assessment of the flash butt welding machine is to be carried out, together with assessment of the condition of the bar ends prior to welding.

4.6.9 Re-test requirements for tensile tests are to be in accordance with UR W2. Failure to meet the specified requirements of either or both additional tests will result in rejection of the sampling length of chain represented and 4.6.2 shall apply.

4.6.10 Re-test requirements for Charpy impact tests are to be in accordance with UR W2. Failure to meet the requirements will result in rejection of the sampling length represented and 4.6.2 shall apply.

4.7 Marking

4.7.1 The chain shall be marked at the following places:

- At each end.
- At intervals not exceeding 100 m.
- On connecting common links.
- On links next to shackles or connecting common links.

4.7.2 All marked links shall be stated on the certificate, and the marking shall make it possible to recognize leading and tail end of the chain. In addition to the above required marking, the first and last common link of each individual charge used in the continuous length shall be traceable and adequately marked.

The marking shall be permanent and legible throughout the expected lifetime of the chain.

4.7.3 The chain shall be marked on the studs as follows:

- Chain grade
- Certificate No.
- Classification Society's stamp

4.7.4 The Certificate number may be exchanged against an abbreviation or equivalent. If so, this shall be stated in the certificate.

4.7.5 The chain certificate shall contain information on number and location of connecting common links. The certificate number and replacement link number may be exchanged against an abbreviation or equivalent. If so, this shall be stated in the certificate.

4.8 Documentation

4.8.1 A complete Chain Inspection and Testing Report in booklet form shall be provided by the chain manufacturer for each continuous chain length. This booklet shall include all

W22
(cont)

dimensional checks, test and inspection reports, NDT reports, process records, photographs as well as any nonconformity, corrective action and repair work.

4.8.2 Individual certificates are to be issued for each continuous single length of chain.

4.8.3 All accompanying documents, appendices and reports shall carry reference to the original certificate number.

4.8.4 The manufacturer will be responsible for storing, in a safe and retrievable manner, all documentation produced for a period of at least 10 years.

5 TESTING AND INSPECTION OF ACCESSORIES**5.1 General**

5.1.1 This section applies to but is not limited to mooring equipment accessories such as detachable connecting links (shackles), detachable connecting plates (triplates), end shackles, swivels and swivel shackles, and subsea connectors.

5.1.2 All accessories are to be subjected to proof load tests, sample break load tests and sample mechanical tests after final heat treatment in the presence of a Surveyor. Where the manufacturer has a procedure to record proof loads and the Surveyor is satisfied with the adequacy of the recording system, he need not witness all proof load tests. The Surveyor is to satisfy himself that the testing machines are calibrated and maintained in a satisfactory condition. Prior to testing and inspection the chain accessories are to be free from scale, paint or other coating.

5.1.3 For accessory production a Manufacturing Procedure Specification (MPS) is to be submitted to the Classification Society that details all critical aspects of accessory production, casting, forging, heat treating (including arrangement and spacing of components in the heat treatment furnaces), quenching, mechanical testing, proof and break loading and NDE.

5.2 Proof and break load tests

5.2.1 All accessories are to be subjected to the proof load specified for the corresponding stud link chain.

5.2.2 Chain accessories are to be tested at the break load prescribed for the grade and size of chain for which they are intended. At least one accessory out of every batch or every 25 accessories, whichever is less, is to be tested.

5.2.2.1 For individually produced, individually heat treated, accessories or accessories produced in small batches (less than 5), alternative testing will be subject to special consideration. Alternative testing is to be approved by the Classification Society and the following additional conditions may apply.

(a) Alternative testing is described in a written procedure and manufacturing procedure specification (MPS).

(b) A finite element analysis is provided at the break load and demonstrates that the accessory has a safety margin over and above the break load of the chain.

(c) Strain age testing (as per approved procedure by the Classification Society) is carried out on the material grade produced to the same parameters at the time of qualification.

(d) If an accessory is of a large size that will make heat treating in batches unfeasible or has a unique design, strain gauges are to be applied during the proof and break load tests during initial qualification and during production. The strain gauge results from production are to be comparable with the results from qualification.

5.2.3 A batch is defined as accessories that originate from the same heat treatment charge and the same heat of steel. Reference sections 2.3 and 2.4.

5.2.4 The accessories which have been subjected to the break load test are to be destroyed and not used as part of an outfit, with the exceptions given in 5.2.5.

W22
(cont)

5.2.5 Where the accessories are of increased dimension or alternatively a material with higher strength characteristics is used, they may be included in the outfit at the discretion of the Classification Society, provided that;

- (a) the accessories are successfully tested at the prescribed breaking load appropriate to the chain for which they are intended, and
- (b) it is verified by procedure tests that such accessories are so designed that the breaking strength is not less than 1.4 times the prescribed breaking load of the chain for which they are intended.
- (c) strain age properties have been carried out on the material grade produced to the same parameters.
- (d) strain gauges are to be applied during the break load test in the high stress locations to monitor that the strains stay within allowable limits.

5.3 Dimensions and dimensional tolerances

5.3.1 At least one accessory (of the same type, size and nominal strength) out of 25 is to be checked for dimensions after proof load testing. The manufacturer is to provide a statement indicating compliance with the purchaser's requirements.

5.3.2 The following tolerances are applicable to accessories:

- a) Nominal diameter: + 5 percent, - 0 percent
- b) Other dimensions: $\pm 2\frac{1}{2}$ percent

These tolerances do not apply to machined surfaces.

5.4 Mechanical tests

5.4.1 Accessories are to be subjected to mechanical testing as described in Section 2.3 and 2.4. Mechanical tests are to be taken from proof loaded full size accessories that have been heat treated with the production accessories they represent. At least one accessory out of every batch or every 25 accessories, whichever is less, is to be tested. Hardness tests are to be carried out on finished accessories. The frequency and locations are to be agreed with the Classification Society. The recorded values are for information only and used as an additional check to verify that the heat treatment process has been stable during the accessory production.

The use of separate representative coupons is not permitted except as indicated in 5.4.5 below.

5.4.2 Test location of forged shackles. Forged shackle bodies and forged Kenter shackles are to have a set of three impact tests and a tensile test taken from the crown of the shackle. Tensile tests on smaller diameter shackles can be taken from the straight part of the shackle, where the geometry does not permit a tensile specimen from the crown. The tensile properties and impact values are to meet the requirements of Table 3 in the locations specified in Figure 3, with the Charpy pieces on the outside radius.

5.4.3 The locations of mechanical tests of cast shackles and cast Kenter shackles can be taken from the straight part of the accessory. The tensile properties and impact values are to meet the requirements of Table 3 in the locations specified in Figure 3.

W22 (cont)

5.4.4 The locations of mechanical tests of other accessories with complex geometries are to be agreed with the Classification Society.

For non-circular sections, $1/4t$ (thickness) from the surface is considered appropriate.

Rolled plates are to be tested to the Standard to which they are produced.

5.4.5 For individually produced (heat treated) accessories or accessories produced in small batches, (less than 5), alternative testing can be proposed to the Classification Society. Each proposal for alternative testing is to be detailed by the manufacturer in a written procedure and submitted to the Classification Society, and the following additional conditions may apply:

(a) If separately forged or cast coupons are used, they are to have a cross-section and, for forged coupon, a reduction ratio similar to that of the accessories represented, and are to be heat treated in the same furnace and quenched in the same tank at the same time, as the actual forgings or castings. Thermocouples are to be attached to the coupon and to the accessories.

(b) If separately forged or cast coupons are agreed, it is to be verified by procedure test that coupon properties are representative of accessory properties.

5.4.6 A batch is defined as accessories that originate from the same heat treatment charge and the same heat of steel. Reference sections 2.3 and 2.4.

5.4.7 Mechanical tests of pins are to be taken as per Figure 3 from the mid length of a sacrificial pin of the same diameter as the final pin. For oval pins the diameter taken is to represent the smaller dimension. Mechanical tests may be taken from an extended pin of the same diameter as the final pin that incorporates a test prolongation and a heat treatment buffer prolongation, where equivalence with mid length test values have been established. The length of the buffer is to be at least equal to 1 pin diameter dimension which is removed after the heat treatment cycle is finished. The test coupon can then be removed from the pin. The buffer and test are to come from the same end of the pin as per Figure 6.

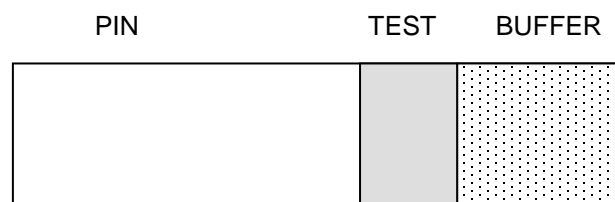

Figure 6 Buffer and test piece location

5.5 Non-destructive examination after proof load testing

5.5.1 All chain accessories are to be subjected to a close visual examination. Special attention is to be paid to machined surfaces and high stress regions. Prior to inspection, chain accessories are to have a suitably prepared surface as per the applied NDE testing standard. All non-machined surfaces are to be sand or shot blast to permit a thorough examination. Where applicable, accessories shall be dismantled for inspection of internal surfaces. All accessories are to be checked by magnetic particles or dye penetrant. UT of accessories may be required by the Classification Society. The acceptance /rejection criteria of UT established for the design is to be met.

W22
(cont)

5.5.2 Testing is to be performed in accordance with a recognized Standard, such as those indicated below, or equivalent. The procedures, together with acceptance/rejection criteria are to be submitted to the Classification Society for review. Manufacturers shall prepare written procedures for NDE. NDE personnel shall be qualified and certified according to ISO 9712, ACCP or equivalent. Personnel qualification to an employer or responsible agency based qualification scheme as SNT-TC-1A may be accepted if the employer's written practice is reviewed and found acceptable and the Level III is ASNT Level III, ISO 9712 Level III or ACCP Professional Level III and certified in the applicable method. NDE operators shall be qualified to at least level II.

Magnetic particle testing (MT) of forgings:

- EN 10228-1, ASTM A275, using wet continuous magnetization technique or equivalent standards such as ISO 4986, IACS Rec 69

Ultrasonic testing (UT) of forgings:

- EN 10228-3, ASTM A388, ISO 13588

Magnetic particle testing (MT) of castings:

- ASTM E709, using wet continuous magnetization technique

Ultrasonic testing (UT) of castings:

- ASTM A609, ISO 13588

All surfaces shall be magnetic particle tested (MT). Testing shall be performed in accordance with standards referenced using the fluorescent technique. As a minimum surfaces shall be free from:

- relevant linear indications exceeding 1.6 mm in transverse direction
- relevant linear indications exceeding 3.2 mm in longitudinal direction
- relevant non-linear indications exceeding 4.8 mm.

When required by the Classification Society, ultrasonic testing is to be carried out on 100% of cast or forged accessories. The acceptance/rejection criteria established for the design is to be met.

5.5.3 The manufacturer is to provide a statement that non destructive examination has been carried out with satisfactory results. This statement should include a brief reference to the techniques and to the operator's qualification.

5.5.4 Weld repairs of finished accessories are not permitted.

5.6 Test failures

5.6.1 In the event of a failure of any test the entire batch represented is to be rejected unless the cause of failure has been determined and it can be demonstrated to the Surveyor's satisfaction that the condition causing the failure is not present in any of the remaining accessories.

5.7 Marking

5.7.1 Each accessory is to be marked as follows:

- Chain grade

W22
(cont)

5.7.2 The Certificate number may be exchanged against an abbreviation or equivalent. If so, this shall be stated in the certificate.

5.8 Documentation

5.8.1 A complete Inspection and Testing Report in booklet form shall be provided by the manufacturer for each order. This booklet shall include all dimensional checks, test and inspection reports, NDT reports, process records and example photographs of components positioned in furnaces, as well as any nonconformity, corrective action and repair work.

5.8.2 Each type of accessory shall be covered by separate certificates.

5.8.3 All accompanying documents, appendices and reports shall carry reference to the original certificate number.

5.8.4 The manufacturer will be responsible for storing, in a safe and retrievable manner, all documentation produced for a period of at least 10 years.

W22

(cont)

Appendix A - Chafing Chain for Single Point Mooring arrangements**A.1. Scope**

These requirements apply to short lengths (approximately 8m) of 76mm diameter chain to be connected to hawsers for the tethering of oil carriers to single point moorings, FPSO's and similar uses.

A.2. Approval of Manufacturing

A.2.1 The chafing chain is to be manufactured by works approved by the Classification Society according to W22.1.3.

A.3. Materials

A.3.1 The materials used for the manufacture of the chafing chain are to satisfy the requirements of W22.2.

A.4. Design, manufacturing, testing and certification

A.4.1 The chafing chain is to be designed, manufactured, tested and certified in accordance with W22.3, W22.4 and W22.5, except that batch heat treatment is permitted.

A.4.2 The arrangement of the end connections is to be of an approved type.

A.4.3 The common link is to be of the stud link type – Grade R3 or R4.

A.4.4 The chafing chain is to be capable of withstanding the breaking test loads of 4884kN (Grade R3) and 6001kN (Grade R4). See Note 1.

A.4.5 The chain lengths shall be proof load tested in accordance with W22.4.2. The test load for Grade R3 is 3242kN and for Grade R4 is 4731kN.

Note 1:

Documented evidence of satisfactory testing of similar diameter mooring chain in the prior 6 month period may be used in lieu of break testing subject to agreement with the Classification Society.

Note 2:

The requirements herein are also applicable to other diameter chafing chains, such as 84 mm and 96 mm, subject to compliance with the proof and break load requirements specified for the chain grade and diameters in Section 3 Table 5.

End of Document
